

東元榮獲國家品質獎

ISO-9001國際品保認證

ISO-14001環境管理認證



東元 變頻馬達

INVERTER DUTY MOTOR

自冷式 AEHLVS AEULVS 系列
強冷式 EVEF EVVF 系列



INVERTER DUTY MOTOR

自冷式 AEHLVS AEULVS 系列

強冷式 EVEF EVVF 系列

目 錄



■ 自冷式變頻馬達

* 規範表	3
* AEHLVS AEULVS 系列特性表	4
* 型號說明	5
* 產品特點	5
* 安裝方式	5
* AEHLVS 外型尺寸圖	6
* AEULVS 外型尺寸圖	8

2



■ 強冷式變頻馬達

* 產品特點	10
* 規範表	10
* 型號說明	11
* 變頻馬達搭配變頻器使用	11
* EVEFYG-S 外型尺寸圖	12
* EVEFYH-S 外型尺寸圖 (附P.G.)	14
* EWFYH-S 外型尺寸圖立式	16
* EWFYH-S 外型尺寸圖 (附P.G.)	18
* 編碼器P.G.接線圖	20
* P.G.輸出介面電路	20



AEULVS



AEHLVS

高效率

提昇能源使用效率，比原標準系列損失降低5%~30%，運轉越久，節省的電費越多。

低振動

精密加工及動平衡，振動等達IEC34-14之R級以上，振動低。

低噪音

高效率損失少→採用較小之外扇、較低之磁通密度設計，精密級加工及動平衡等，噪音均降低。

■ 規範表

項 目		標 準	規 範	
規 格	種 類	三相鼠籠式感應電動機(SCIM)		
	設 計 依 據	國際電工委員會(IEC)，中國國家標準(CNS)		
	電 壓	額定電壓 220V, 380V, 440V, 或雙電壓		
	頻 率	額定頻率 50Hz 或 60Hz		
	輸 出 馬 力	1/4 ~ 270HP		
	時 間 額 定	連續使用額定，使用系數S.F.：1.0		
	框 號	63 ~ 315M		
	保 護 方 式	全密閉外扇型(IP54)		
	冷 卻 方 式	全密IC411自帶外扇冷卻		
	安 裝 方 式	AEHLVS IM-1001：水平腳座安裝，AEULVS IM-3011：凸緣型安裝		
適 用	轉 矩 特 性	定轉矩：3：1 遞減轉矩：20：1，轉矩成正比於轉速平方遞減		
	電 源	電壓變動率：± 10%以內 頻率變動率：± 5%以內 綜合變動率：以上兩點絕對值之和在10%以內，但頻率變動在±5%以內		
	使 用 環 境	場 所	一般屋內	
		周 溫	-15°C ~ 40°C	
		濕 度	相對濕度 90%以下 (但不能凝結)	
	標 高	海拔1,000公尺以下		
	帶 動 方 式	直接耦合(撓性連接器)或皮帶連接式		
轉 向	雙轉向			
啟 動 方 式	全壓直接啟動			
結 構	軸 承	框號250以上為注油式，雙面開放式滾珠或滾筒軸承。 其餘為預注油脂式，雙遮蓋密閉式滾珠軸承。		
	出 線 盒	鋼板材質超大容量附電纜線進口孔，並能作 90°C 旋轉安裝。 由負載端視之位於框架左側，標準品不附電纜頭。		
	出 口 線	出口線數最多12條，附有接線端子。		
	定 子 絕 緣	F 級絕緣		
	塗 裝	防鏽處理，酚系樹脂底漆，面漆顏色為藍灰色Munsell (7.5B 3.5/0.5)		
	螺 紋	國家標準組織 ISO-M公制		
測 試 程 序	依據CNS 14400 C4482、IEEE-112方法B 使用全壓啟動測試			
溫 昇	定子繞阻溫昇：電阻法 100°C以下			
附 件	熱保護器：145°C 常閉型			

型號說明

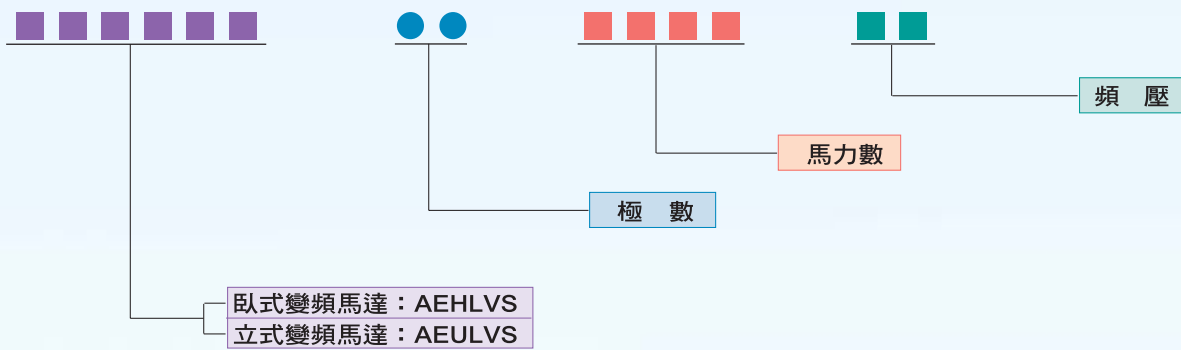

產品特點

美觀方便

- 全密封式鑄鐵框、托架結構設計，外型紮實，具信賴性。
- 塗裝使用酚系樹脂底漆，優藝堅光面漆，外觀亮麗精緻，深具價值感。
- 軸端均加標準IEC / BS攻牙，易於配合不同負載，使用更加具選擇及方便性。

經濟實用

- 提昇能源使用效率，具高效率、低振動、低噪音之特性，符合環保要求，經濟實用。
- 品質精密，性能優越，具溫昇低、熱容量大，搭配向量控制、變頻器等驅動元件時，可做較廣範圍速度控制運用，適用於各種產業機械之廣大市場。
- 採自帶風扇冷卻之設計，外型尺寸和標準馬達相同，不多佔空間，經濟效益高。

功能特性

- 本馬達符合國際上重要性能及品管規範，並可採用多種起動方式，為低噪音、長壽命之電動機，具工商業上之經濟實用價值。
- 全密封式構造，保護方式IP54，防塵、防水濺符合國際標準，安全更具保障性。
- 符合安全規範EN294之新風罩設計，銷歐洲須CE mark時，可直接適用。
- 風罩新型設計榮獲國家專利(新型第131186號)，具有造型美觀、降低噪音、增加風量與增安全性之優越功能。
- 線圈採H級AI線，並經兩次凡立水處理，對耐變頻突波及惡劣環境也能勝任。
- F#80及F#160~250具坐臥兩用互換性，L、F托架獨立組裝，改造拆裝容易。
- 詳檢實驗室獲得美國商務部(DOC)NVLAP認證為亞洲第一家，精密度高，品質信賴性佳。

安裝方式

橫臥型安裝方式		豎立型安裝方式 (附 D Flange)		豎立型安裝方式 (附 C Flange)		坐臥兩用型安裝方式	
IM-1001 (IM B3)		IM-3001(IM B5)		IM-3601(IM B14)		IM-2001(IM B35)	(附 D Flange)
水平軸 腳貼地		水平軸		水平軸		水平軸 腳貼地	
IM-1011 (IM V5)		IM-3011(IM V1)		IM-3611(IM B18)		IM-2101(IM B34)	(附 C Flange)
垂直軸 軸端向下 腳貼牆壁		垂直軸 軸端向下		垂直軸 軸端向下		水平軸 腳貼地	

AEHLVS 外型尺寸圖

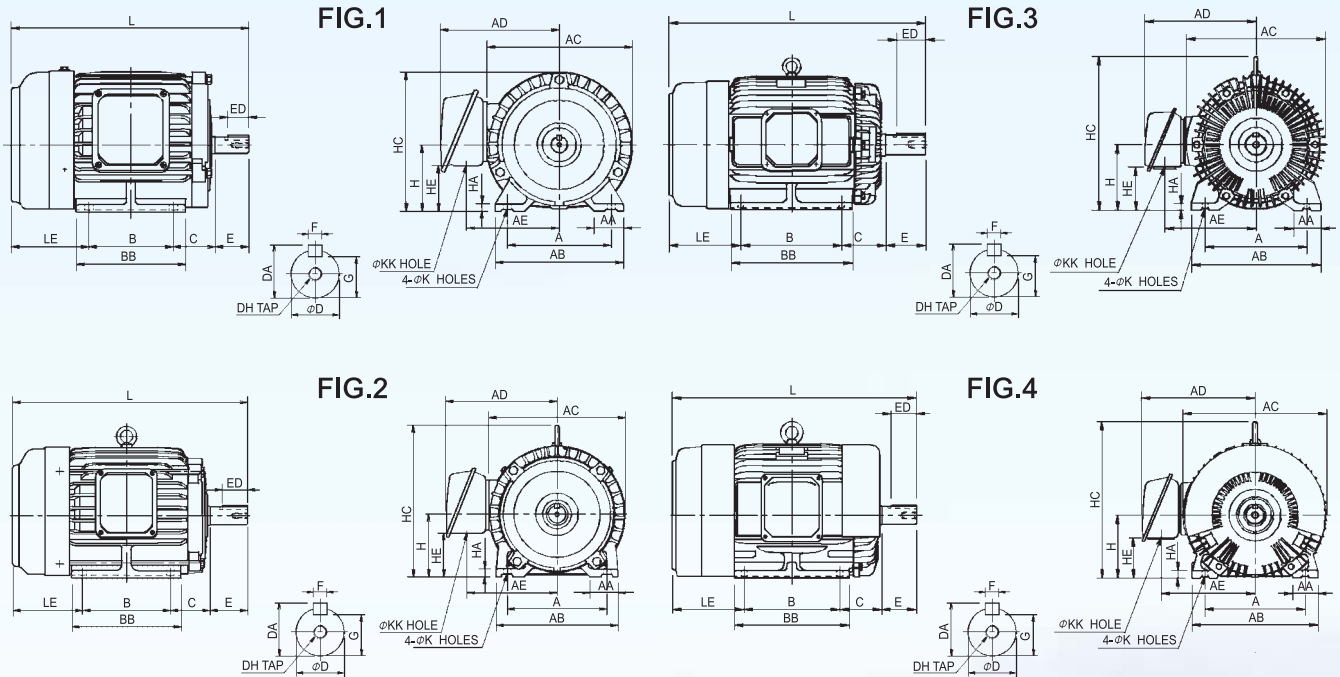

輸出馬力 (HP)			框號	圖號	A	AA	AB	AC	AD	AE	B	BA	BB	C	H	HA	HC	HD
2P	4P	6P																
0.25	0.25	—	63	1	100	28	120	144	123	93	80	—	100	40	63	8	135	—
0.5	0.5	0.25	71		112	35.5	140	162	133	103	90	—	115	45	71	8	152	—
1	1	0.5	80		125	35.5	155	177	144	112	100	—	130	50	80	9	168.5	—
2	2	1	90L		140	35.5	170	200	157	125	125	—	150	56	90	10	190	—
—	3	2	100L	2	160	45	195	219	180	145	140	—	175	63	100	12.5	—	243
5	5	3	112M		190	45	224	238	189	154	140	—	175	70	112	14	—	265
7.5	7.5	5	132S		216	45	250	273	225	180	140	—	175	89	132	16	—	310
—	10	7.5	132M		216	45	250	273	225	180	178	—	212	89	132	16	—	310
15	15	10	160M	3	254	50	300	334	263	218	210	—	250	108	160	18	—	377
20	20	15	160L		254	50	300	334	263	218	254	—	300	108	160	18	—	377
25	20	15	180MA	4	279	75	355	382	305	250	241	—	297	121	180	20	—	421
—	25	20	180MC	3	279	75	355	382	305	250	241	—	297	121	180	20	—	421
40	—	—	180LA	4	279	75	355	382	305	250	279	—	335	121	180	20	—	421
—	40	25	180LC	3	279	75	355	382	305	250	279	—	335	121	180	20	—	421
50	—	—	200LA	4	318	80	400	458	362	299	305	—	365	133	200	25	—	499
—	50	40	200LC		318	80	400	458	362	299	305	—	365	133	200	25	—	499
60	60	50	200LC	4	318	80	400	458	362	299	305	—	365	133	200	25	—	499
75	—	—	225SA	5	356	100	450	510	411	337	286	—	350	149	225	30	—	550
—	75	60	225SC		356	100	450	510	411	337	286	—	350	149	225	30	—	550
100	—	—	250SA		406	110	500	545	499	384	311	—	385	168	250	32	—	592
—	100	75	250SC		406	110	500	545	499	384	311	—	385	168	250	32	—	592
125	—	—	250MA	406	110	500	545	499	384	349	—	425	168	250	32	—	592	
—	125	100	250MC	406	110	500	545	499	384	349	—	425	168	250	32	—	592	
150	—	—	280S	5	457	110	560	625	610	455	368	110	445	190	280	36	—	710
—	150	125	280S		457	110	560	625	610	455	368	110	445	190	280	36	—	710
175	—	—	280M		457	110	560	625	610	455	419	130	495	190	280	36	—	710
—	175	150	280M		457	110	560	625	610	455	419	130	495	190	280	36	—	710
200	—	—	315S	7	508	115	615	625	610	455	406	115	490	216	315	40	—	743
215	—	—	315S		508	115	615	625	610	455	406	115	490	216	315	40	—	743
—	200	175	315S		508	115	615	625	610	455	406	115	490	216	315	40	—	743
250	—	—	315M		508	115	615	625	610	455	457	115	540	216	315	40	—	743
270	—	—	315M	508	115	615	625	610	455	457	115	540	216	315	40	—	743	
—	250	200	315M	508	115	615	625	610	455	457	115	540	216	315	40	—	743	
—	270	215	315M	508	115	615	625	610	455	457	115	540	216	315	40	—	743	

★ 註：1.軸心直徑D公差：φ11-φ28：j6 φ38-φ48：k6 φ55-φ95：m6。
2.軸心高度H公差：框號250(含)以下：+0,-0.5，框號280以上：+0,-1。
3.框號280以上EE值為可用軸長。

4.以上數值如有變更，恕不另行通知。

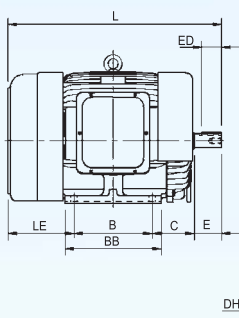

FIG.5

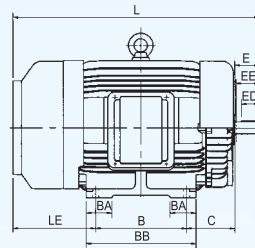
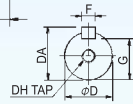
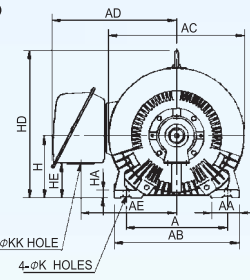

FIG.7

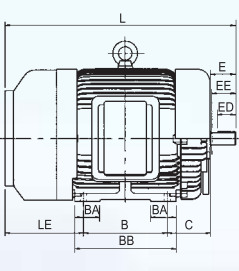
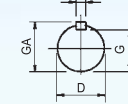
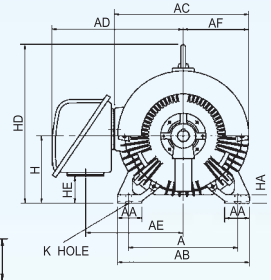
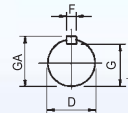
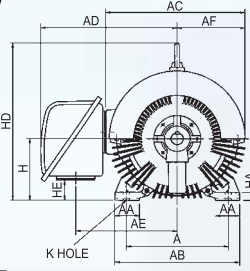

FIG.6



Dimension in mm

HE	K	KK	L	LE	軸 端							軸 承		概略重量 Kgs	框號
					D	E	ED	F	G	GA	DH	負載側	非負載側		
29	7	22	219	76	11	23	18	4	8.5	12.5	M4X8	6201ZZ	6201ZZ	8.5	63
54	7	22	250.5	85.5	14	30	24	5	11	16	M5X10	6202ZZ	6202ZZ	11.5	71
55	10	22	282.5	92.5	19	40	25	6	15.5	21.5	M6X12	6204ZZ	6204ZZ	17	80
65	10	22	332.5	101.5	24	50	32	8	20	27	M8X16	6205ZZ	6205ZZ	24	90L
71	12	28	374.5	111.5	28	60	40	8	24	31	M10X20	6206ZZ	6305ZZ	37	100L
83	12	28	391.5	121.5	28	60	40	8	24	31	M10X20	6306ZZ	6306ZZ	46	112M
83	12	35	454	145	38	80	64	10	33	41	M12X24	6308ZZ	6306ZZ	68	132S
83	12	35	492	145	38	80	64	10	33	41	M12X24	6308ZZ	6306ZZ	79	132M
108	14.5	35	608	180	42	110	80	12	37	45	M16X32	6309ZZ	6307ZZ	125	160M
108	14.5	35	652	180	42	110	80	12	37	45	M16X32	6309ZZ	6307ZZ	140	160L
119	14.5	52	672	200	48	110	80	14	42.5	51.5	M16X32	6311ZZC3	6310ZZC3	179	180MA
119	14.5	52	672	200	48	110	80	14	42.5	51.5	M16X32	6311ZZ	6310ZZ	195	180MC
119	14.5	52	710	200	55	110	80	16	49	59	M20X40	6312ZZC3	6310ZZC3	198	180LA
119	14.5	52	710	200	55	110	80	16	49	59	M20X40	6312ZZ	6310ZZ	223	180LC
129	18.5	65	774.5	226.5	55	110	80	16	49	59	M20X40	6312ZZC3	6212ZZC3	312	200LA
129	18.5	65	804.5	226.5	60	140	110	18	53	64	M20X40	6314ZZ	6212ZZ	324	200LC
153	18.5	92	786	241	55	110	80	16	49	59	M20X40	6312ZZC3	6212ZZC3	400	225SA
153	18.5	92	816	241	65	140	110	18	58	69	M20X40	6315ZZ	6213ZZ	412	225SC
139	24	92	852.5	263.5	55	110	80	16	49	59	M20X40	6313C3	6313C3	449	250SA
139	24	92	882.5	264	75	140	110	20	67.5	79.5	M20X40	NU316	6313	508	250SC
139	24	92	890.5	263.5	55	110	80	16	49	59	M20X40	6313C3	6313C3	517	250MA
139	24	92	920.5	264	75	140	110	20	67.5	79.5	M20X40	NU316	6313	575	250MC
91	24	—	1012	344	55	110	80	16	49	59	—	6314C3	6314/C3VL0241	680	280S
91	24	—	1072	344	85	170	140	22	76	90	—	NU320C3	6316/C3VL0241	760	280S
91	24	—	1062	343	55	110	80	16	49	59	—	6314C3	6314/C3VL0241	725	280M
91	24	—	1122	343	85	170	140	22	76	90	—	NU320C3	6316/C3VL0241	820	280M
126	28	—	1101	369	55	110	80	16	49	59	—	6314C3	6314/C3VL0241	840	315S
126	28	—	1161	369	95	170	140	25	86	100	—	NU320C3	6316/C3VL0241	970	315S
126	28	—	1152	369	55	110	80	16	49	59	—	6314C3	6314/C3VL0241	1000	315M
126	28	—	1212	369	95	170	140	25	86	100	—	NU320C3	6316/C3VL0241	1090	315M

AEULVS 外型尺寸圖

FIG.1

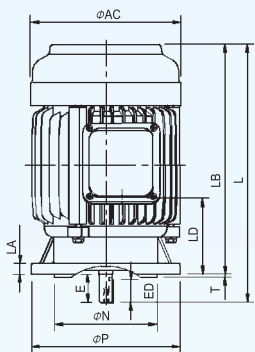

FIG.2

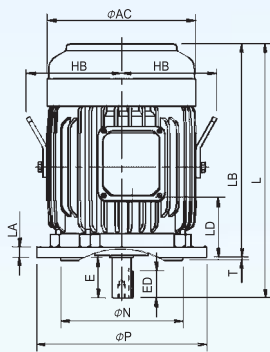

FIG.3

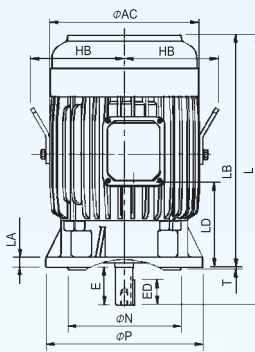
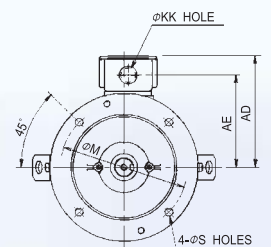
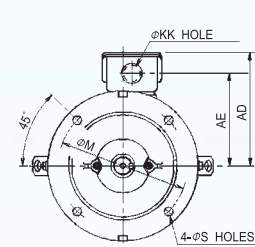
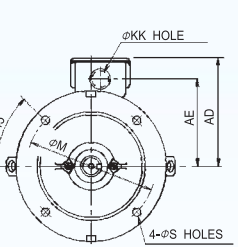
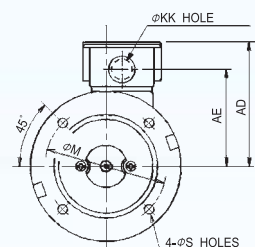
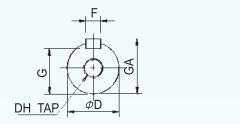
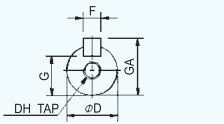
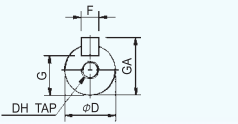
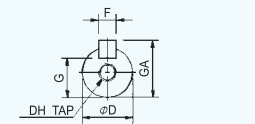
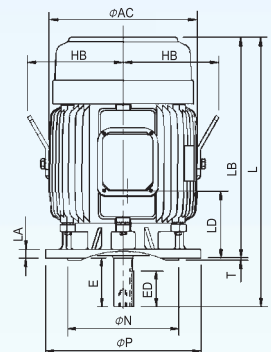
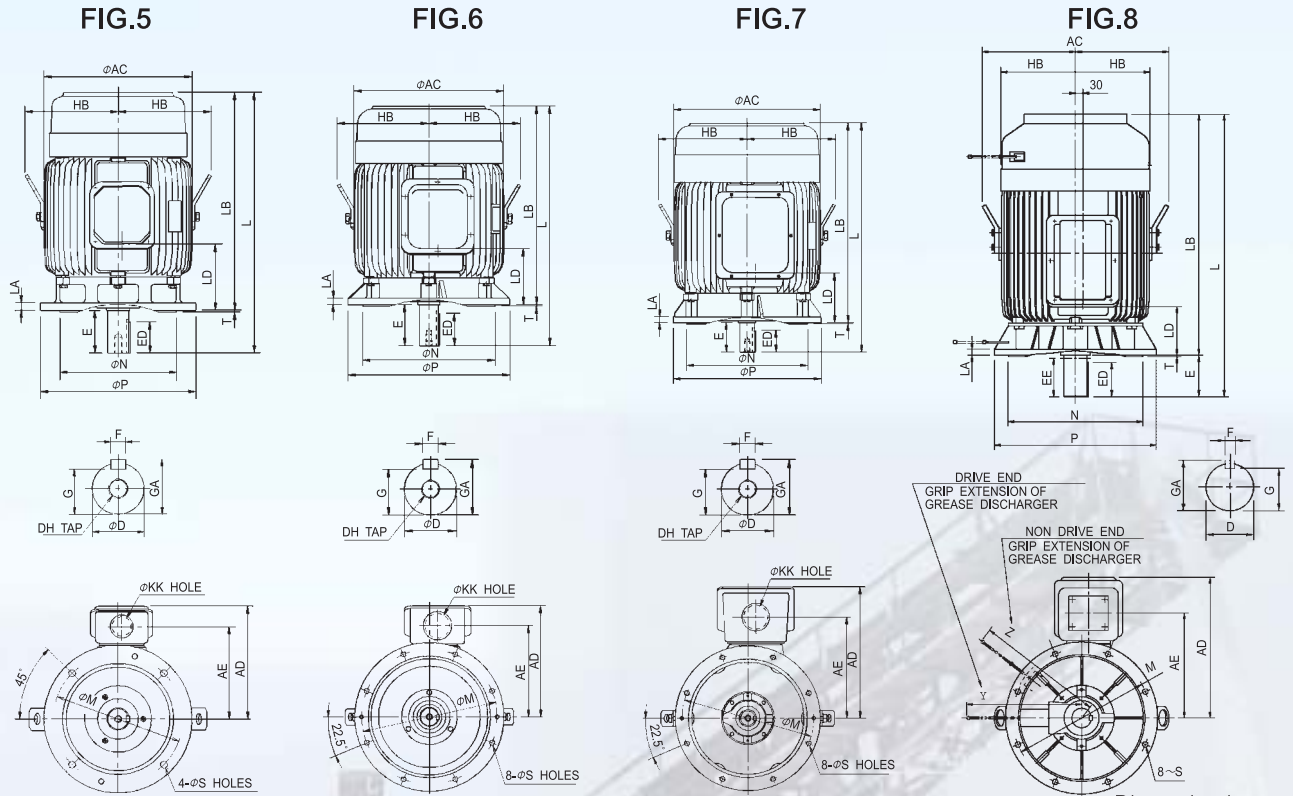

FIG.4



輸出馬力 (HP)			框號	圖號	AC	AD	AE	HB	KK	L	LA	LB	LD	M	N	P	
2P	4P	6P															
0.25	0.25	—	63	1	144	123	93	—	22	248	12	225	74	130	110	160	
0.5	0.5	0.25	71		162	133	103	—	22	277.5	12	247.5	82	130	110	160	
1	1	0.5	80	2	177	144	112	—	22	282	12	242	60	165	130	200	
2	2	1	90L	3	200	157	125	—	22	371.5	12	321.5	113	165	130	200	
3			2	100L	2	219	180	145	140	28	374.5	16	314.5	88	215	180	250
5	5	3	112M	3	238	189	154	150	28	431	16	371	135	215	180	250	
7.5	7.5	5	132S	2	273	224	180	169	35	454	20	374	97	265	230	300	
10			7.5		132M	273	224	180	169	35	492	20	412	116	265	230	300
15	15	10	160M	4	334	263	218	217	35	608	20	498	151	300	250	350	
20			15		160L	334	263	218	217	35	652	20	542	173	300	250	350
30	—	—	180MA	5	382	305	250	241	52	672	20	562	170.5	350	300	400	
—	25	20	180MC		382	305	250	241	52	672	20	562	170.5	350	300	400	
—	30	—	180LA		382	305	250	241	52	710	20	600	189.5	350	300	400	
—	40	25	180LC		382	305	250	241	52	710	20	600	189.5	350	300	400	
50	—	—	200LA	6	458	362	299	286	65	774.5	20	664.5	194.5	400	350	450	
60			50		40	200LC	458	362	299	286	65	804.5	20	664.5	194.5	400	350
—	50	60	225SA	7	510	411	337	312	92	786	22	676	190	500	450	550	
—	75	60	225SC		510	411	337	312	92	816	22	676	190	500	450	550	
100	—	—	250SA	7	545	499	384	329.5	92	882.5	22	742.5	182.5	500	450	550	
—	100	75	250SC		545	499	384	329.5	92	882.5	22	742.5	182.5	500	450	550	
125	—	—	250MA		545	499	384	329.5	92	890.5	22	780.5	201.5	500	450	550	
—	125	100	250MC		545	499	384	329.5	92	920.5	22	780.5	201.5	500	450	550	
150	150	125	280S	8	610	610	455	383	—	1012	25	902	156	600	550	660	
—			150		280S	610	610	455	383	—	1072	25	902	156	600	550	660
175			—		280M	610	610	455	383	—	1101	25	991	200	600	550	660
—	175	150	280M	610	610	455	383	—	1161	25	991	200	600	550	660		
200	—	—	315S	8	610	610	455	383	—	1101	25	991	200	600	550	660	
215			200		175	315S	610	610	455	383	—	1161	25	991	200	600	550
250	—	—	315M	8	610	610	455	383	—	1152	25	1042	226	600	550	660	
270	250	200	315M		610	610	455	383	—	1212	25	1042	226	600	550	660	

★ 註：1.軸心直徑D公差：Φ11-Φ28：j6 Φ38-Φ48：k6 Φ55-Φ95：m6。 2.引線直徑N公差：h7。
3.框號280以上EE值為可用軸長。 4.以上數值如有變更，恕不另行通知。



Dimension in mm

S	T	軸端								軸承		概略重量 Kgs	框號
		D	E	ED	EE	F	G	GA	DH	負載側	非負載側		
10	3.5	11	23	18	—	4	8.5	12.5	M4X8	6201ZZ	6201ZZ	9.5	63
10	3.5	14	30	24	—	5	11	16	M5X10	6202ZZ	6202ZZ	12.4	71
12	3.5	19	40	25	—	6	15.5	21.5	M6X12	6204ZZ	6204ZZ	19	80
12	3.5	24	50	32	—	8	20	27	M8X16	6205ZZ	6205ZZ	27	90L
14.5	4	28	60	40	—	8	24	31	M10X20	6206ZZ	6305ZZ	40	100L
14.5	4	28	60	40	—	8	24	31	M10X20	6306ZZ	6306ZZ	51	112M
14.5	4	38	80	64	10	10	33	41	M12X24	6308ZZ	6306ZZ	73	132S
14.5	4	38	80	64	—	10	33	41	M12X24	6308ZZ	6306ZZ	84	132M
18.5	5	42	110	80	—	12	37	45	M16X32	6309ZZ	6307ZZ	133	160M
18.5	5	42	110	80	—	12	37	45	M16X32	6309ZZ	6307ZZ	148	160L
18.5	5	48	110	80	—	14	42.5	51.5	M16X32	6311ZZC3	6310ZZC3	187	180MA
18.5	5	48	110	80	—	14	42.5	51.5	M16X32	6311ZZ	6310ZZ	203	180MC
18.5	5	55	110	80	—	16	49	59	M20X40	6312ZZC3	6210ZZC3	206	180LA
18.5	5	55	110	80	—	16	49	59	M20X40	6312ZZ	6310ZZ	231	180LC
18.5	5	55	110	80	—	16	49	59	M20X40	6312ZZC3	6212ZZC3	322	200LA
18.5	5	60	140	110	—	18	53	64	M20X40	6314ZZ	6212ZZ	334	200LC
18.5	5	55	110	80	—	16	49	59	M20X40	6312ZZC3	6212ZZC3	420	225SA
18.5	5	65	140	110	—	18	58	69	M20X40	6315ZZ	6213ZZ	432	225SC
18.5	5	55	110	80	—	16	49	59	M20X40	6313C3	6313C3	469	250SA
18.5	5	75	140	110	—	20	67.5	79.5	M20X40	NU316	6313	528	250SC
18.5	5	55	110	80	—	16	49	59	M20X40	6313C3	6313C3	537	250MA
18.5	5	75	140	110	—	20	67.5	79.5	M20X40	NU316	6313	595	250MC
24	6	55	110	80	104	16	49	59	—	6314C3	6314/C3VL0241	750	280S
24	6	85	170	140	157	22	76	90	—	NU320C3	6316/C3VL0241	840	280S
24	6	55	110	80	104	16	49	59	—	6314C3	6314/C3VL0241	800	280M
24	6	85	170	140	157	22	76	90	—	NU320C3	6316/C3VL0241	910	280M
24	6	55	110	80	104	16	49	59	—	6314C3	6314/C3VL0241	930	315S
24	6	95	170	140	157	25	86	100	—	NU320C3	6316/C3VL0241	1070	315S
24	6	55	110	80	104	16	49	59	—	6314C3	6314/C3VL0241	1100	315M
24	6	95	170	140	157	25	86	100	—	NU320C3	6316/C3VL0241	1170	315M

強冷式 變頻馬達

EVEF EVVF 系列

■ 產品特點

國際規格 · 各界通用

- 全自動鑄造設備自鑄精密外殼，全新設計，外型嶄新美觀。
- 安裝尺寸及公差全部符合IEC國際統一規格，舉世通用，互換性高，保養簡便，適合各界需要。

品質精密 · 信賴度高

- 配合電腦設計，以最新式自動機械精密加工，電子儀器檢驗，一貫作業生產。
- 採用專利繞線方式及專用軸承，精密度高，特性符合中國國家標準(CNS)及國際電氣協會(IEC)標準，信賴度高。

節約能源 · 堅固耐用

- 全密封式構造，防塵、防水滴及油沫(污)。
- 高效率冷卻構造，減少風損，節約能源。
- 線圈採H級AI線，並經2次凡立水處理，馬達最小CIV值F#132(含)以下為2000V，F#160(含)以上為2200V，對耐變頻突波及惡劣環境也能勝任。

強勁安靜 · 反應靈敏

- 採用特殊槽壓鑄鋁轉子，起動轉矩大，慣性小，節省起動停止時間。
- 高效率分離式冷卻風扇，體積小，噪音低。
- 採用耐振動、耐衝擊、高精度之『編碼器』速度回授，控制精確，信號反應靈敏。

■ 規範表

項 目		標 準 規 範			
規	種 類	低壓三相鼠籠式感應電動機(SCIM)			
	保 護 方 式	馬達部份：IP54(全密式)；附送風機部份：IP54			
	安 裝 方 式	EVEF：水平腳座安裝(IM 1001) EVVF：框號71~250為凸托架安裝(IM 3001、3011) 框號280為凸托架安裝(IM 3011)			
	冷 卻 方 式	IC416：強制冷卻附送風機。 框號：200以下單相50/60Hz 200~240V 框號：225以上隨馬達主電源變動			
	框 號	EVEF：71 ~ 315M EVVF：71 ~ 280M.			
	極 數	2P	4P	6P	8P
	額 定 輸 出 (HP)	1/2 ~ 270	1/2 ~ 270	1/4 ~ 215	25 ~ 150
	馬 達 電 源	三相220,380,415,440,460V 50 or 60Hz			
	時 間 額 定	連續額定			
	轉 矩 特 性	定轉矩：10：1 遞減轉矩：20：1，轉矩成正比於轉速平方遞減			
格	啟 動 轉 矩	125%額定轉矩			
	絕 緣 等 級	F級(附熱保護器 - 常閉型)			
使 用 環 境	場 所	一般屋內(避免腐蝕性氣體及多塵埃之處)			
	標 高	海拔1,000公尺以下			
	周 溫	-15°C ~ 40°C			
	濕 度	相對濕度 80%以下 (但不能凝結)			
標 準 轉 向		面向軸端視之，為逆時針方向旋轉			
負 載 連 結 方 式		直接耦合(撓性連接器)或皮帶連接式			
塗 裝		防銹處理+酚樹脂底漆+噴塗漆+(Munsell 7.5B 3.5/0.5)			
選 擇 性 附 件		1.回授裝置：P.G(ENCODER)，編碼器，600P.P.R 框號71~250：12~24V電壓 框號280以上：12V電壓 2.熱保護器：常閉型			

■ 型號說明

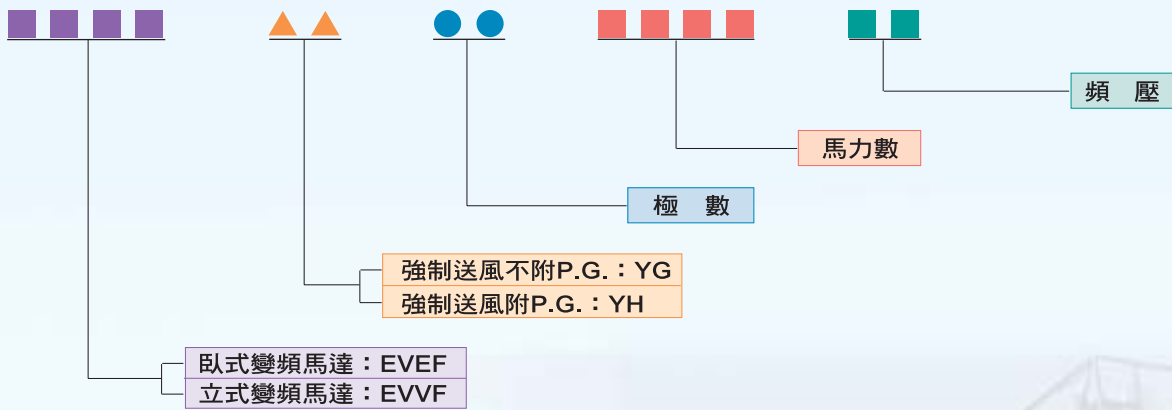

■ 變頻馬達搭配變頻器使用

變頻器	型號及功能	使用馬達範圍
	7300EV ● Sensorless向量控制 ● PID機能 ● 彈性擴充機能：Copy unit ● PC / PDA連線機能 ● 2 in / 1 out擴充卡 ● 完整保護機能	1/4 ~3 HP 220V
		1 ~ 3 HP 440V
	7300CV ● Sensorless向量控制 ● 內建PLC / PID控制機能 ● PC / PDA連線機能 ● 內建EMC filter ● 彈性擴充機能：Copy unit	1/2 ~ 40 HP 220V
		1 ~ 75 HP 440V
	7200MA ● 中、英文LCD操作器及參數拷貝機能 ● PG回授介面標準內含，可作V / F + PG閉迴路控制 ● 標準內含PID及PLC、計時機能及脈波輸出 ● 特殊應用機能規劃軟體(C.A.S.E.) ● Sensorless向量控制	1 ~ 40 HP 220V
		1 ~ 75 HP 440V
	7200GS ● 4模式控制：PID+AES / V.F / V/F+PG / Sensorless Vector+靜態Auto tuning ● 中、英文LCD操作器及參數拷貝機能 ● 內含全系列C.M.Chock有效抑制共模雜訊	25 ~ 100 HP 220V
		25 ~ 400 HP 440V

強冷式 變頻馬達 EVEF EVVF 系列

FIG.5

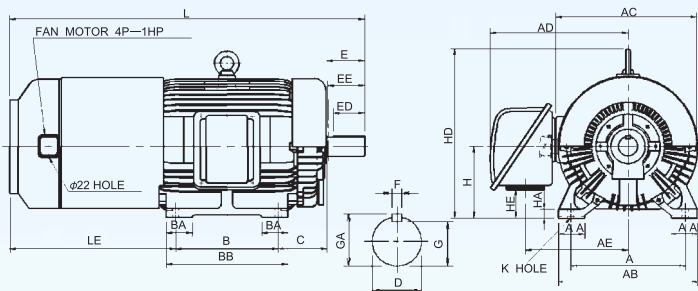
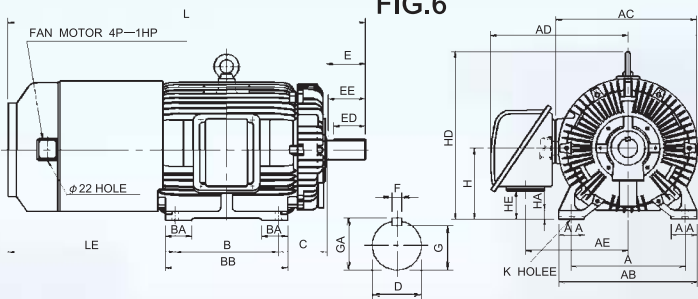

FIG.6



- 註：1. 軸心直徑D公差： $\phi 14-\phi 28$ ：j6，
 $\phi 38-\phi 48$ ：k6， $\phi 55-\phi 95$ ：m6。
2. 軸心高度H公差： $71\sim 280\text{mm}$ ： $+0,-0.5$ ，
 $280\sim 315\text{mm}$ ： $+0,-1$ 。
3. 以上數值如有變更，恕不另行通知。

Dimension in mm

HE	K	KK	L	LE	LL	軸 端							軸 承		概略重量 Kgs	框號	
						D	E	EE	ED	F	G	GA	DH	負載側			非負載側
54	7	22	345	180	---	14	30	---	24	5	11.0	16.0	M5X10	6202ZZ	6202ZZ	12	71
55	10	22	373	183	---	19	40	---	25	6	15.5	21.5	M6X12	6204ZZ	6204ZZ	16	80
65	10	22	427	196	---	24	50	---	32	8	20.0	27.0	M8X16	6205ZZ	6205ZZ	24	90L
71	12	28	461	198	---	28	60	---	40	8	24.0	31.0	M10X20	6206ZZ	6305ZZ	33	100L
83	12	28	493	223	---	28	60	---	40	8	24.0	31.0	M10X20	6306ZZ	6306ZZ	43	112M
83	12	35	538	229	---	38	80	---	64	10	33.0	41.0	M12X24	6308ZZ	6306ZZ	63	132S
83	12	35	576	229	---	38	80	---	64	10	33.0	41.0	M12X24	6308ZZ	6306ZZ	79	132M
108	14.5	35	743	315	---	42	110	---	80	12	37.0	45.0	M16X32	6309ZZ	6307ZZ	127	160M
108	14.5	35	787	315	---	42	110	---	80	12	37.0	45.0	M16X32	6309ZZ	6307ZZ	149	160L
119	14.5	52	800	328	---	48	110	---	80	14	42.5	51.5	M16X32	6311ZZC3	6310ZZC3	190	180MA
119	14.5	52	800	328	---	48	110	---	80	14	42.5	51.5	M16X32	6311ZZ	6310ZZ	187	180MC
119	14.5	52	838	328	---	55	110	---	80	16	49.0	59.0	M20X40	6312ZZC3	6310ZZC3	218	180LA
119	14.5	52	838	328	---	55	110	---	80	16	49.0	59.0	M20X40	6312ZZ	6310ZZ	220	180LC
128	18.5	65	863	315	---	55	110	---	80	16	49.0	59.0	M20X40	6312C3	6212ZZC3	292	200LA
128	18.5	65	893	315	---	60	140	---	110	18	53.0	64.0	M20X40	6314	6212ZZC3	324	200LC
153	18.5	92	1020	475	---	55	110	---	80	16	49.0	59.0	M20X40	6312C3	6212ZZC3	358	225SA
153	18.5	92	1050	475	---	65	140	---	110	18	58.0	69.0	M20X40	6315	6213ZZ	385	225SC
139	24.0	92	1115	526	19.0	55	110	---	80	16	49.0	59.0	M20X40	6313C3	6313C3	518	250SA
139	24.0	92	1145	526	19.0	75	140	---	110	20	67.5	79.5	M20X40	NU316	6313	532	250SC
139	24.0	92	1172	545	28.5	55	110	---	80	16	49.0	59.0	M20X40	6313C3	6313C3	522	250MA
139	24.0	92	1202	545	28.5	75	140	---	110	20	67.5	79.5	M20X40	NU316	6313	534	250MC
91	24.0	---	1382	714	---	55	110	104	80	16	49.0	59.0	---	6314C3	6314C3	850	280SA
91	24.0	---	1442	714	---	85	170	157	140	22	76.0	90.0	---	NU320C3	6316	910/990/1070	280SC
91	24.0	---	1432	713	---	55	110	104	80	16	49.0	59.0	---	6314C3	6314C3	895	280MA
91	24.0	---	1492	713	---	85	170	157	140	22	76.0	90.0	---	NU320C3	6316	980/990/1000	280MC
126	28.0	---	1471	739	---	55	110	104	80	16	49.0	59.0	---	6314C3	6314C3	1010	315SA
126	28.0	---	1531	739	---	95	170	157	140	25	86.0	100.0	---	NU320C3	6316	1140/1130/1120	315SA
126	28.0	---	1522	739	---	55	110	104	80	16	49.0	59.0	---	6314C3	6314C3	1170	315MA
126	28.0	---	1582	739	---	95	170	157	140	25	86.0	100.0	---	NU320C3	6316	1230/1260/1290	315MC

強冷式 變頻馬達

EVEF EVVF 系列

FIG.5

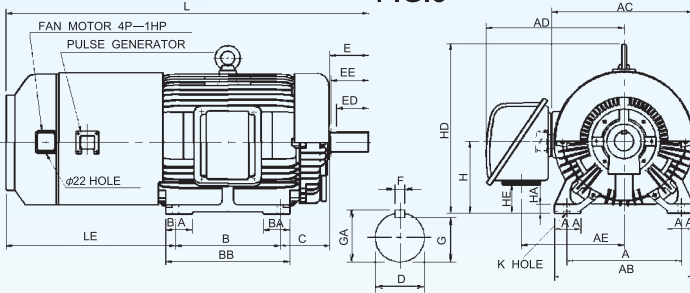
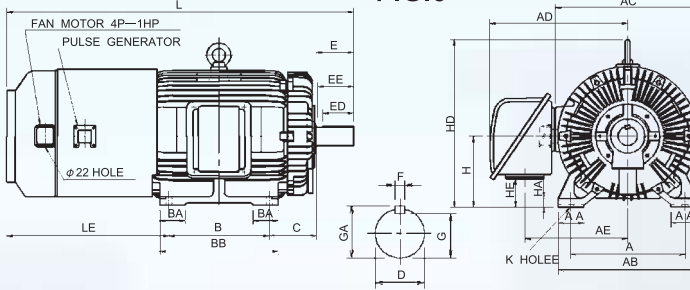

FIG.6



- 註：1. 軸心直徑D公差： $\phi 14-\phi 28 : j6$ ，
 $\phi 38-\phi 48 : k6$ ， $\phi 55-\phi 95 : m6$ 。
 2. 軸心高度H公差： $71\sim 280\text{mm} : +0,-0.5$ ，
 $280\sim 315\text{mm} : +0,-1$ 。
 3. 以上數值如有變更，恕不另行通知。



Dimension in mm

HE	K	KK	L	LE	LL	軸 端							軸 承		概略重量 Kgs	框號	
						D	E	EE	ED	F	G	GA	DH	負載側			非負載側
54	7	22	345	180	---	14	30	---	24	5	11.0	16.0	M5X10	6202ZZ	6202ZZ	13	71
55	10	22	373	183	---	19	40	---	25	6	15.5	21.5	M6X12	6204ZZ	6204ZZ	16	80
65	10	22	427	196	---	24	50	---	32	8	20.0	27.0	M8X16	6205ZZ	6205ZZ	24	90L
71	12	28	461	198	---	28	60	---	40	8	24.0	31.0	M10X20	6206ZZ	6305ZZ	33	100L
83	12	28	493	223	---	28	60	---	40	8	24.0	31.0	M10X20	6306ZZ	6306ZZ	44	112M
83	12	35	538	229	---	38	80	---	64	10	33.0	41.0	M12X24	6308ZZ	6306ZZ	63	132S
83	12	35	576	229	---	38	80	---	64	10	33.0	41.0	M12X24	6308ZZ	6306ZZ	80	132M
108	14.5	35	743	315	---	42	110	---	80	12	37.0	45.0	M16X32	6309ZZ	6307ZZ	127	160M
108	14.5	35	787	315	---	42	110	---	80	12	37.0	45.0	M16X32	6309ZZ	6307ZZ	149	160L
119	14.5	52	800	328	---	48	110	---	80	14	42.5	51.5	M16X32	6311ZZC3	6310ZZC3	191	180MA
119	14.5	52	800	328	---	48	110	---	80	14	42.5	51.5	M16X32	6311ZZ	6310ZZ	188	180MC
119	14.5	52	838	328	---	55	110	---	80	16	49.0	59.0	M20X40	6312ZZC3	6310ZZC3	219	180LA
119	14.5	52	838	328	---	55	110	---	80	16	49.0	59.0	M20X40	6312ZZ	6310ZZ	221	180LC
128	18.5	65	983	435	---	55	110	---	80	16	49.0	59.0	M20X40	6312C3	6212ZZC3	295	200LA
128	18.5	65	1013	435	---	60	140	---	110	18	53.0	64.0	M20X40	6314	6212ZZC3	328	200LC
153	18.5	92	1210	665	---	55	110	---	80	16	49.0	59.0	M20X40	6312C3	6212ZZC3	363	225SA
153	18.5	92	1240	665	---	65	140	---	110	18	58.0	69.0	M20X40	6315	6213ZZ	390	225SC
139	24.0	92	1316	727	19.0	55	110	---	80	16	49.0	59.0	M20X40	6313C3	6313C3	525	250SA
139	24.0	92	1346	727	19.0	75	140	---	110	20	67.5	79.5	M20X40	NU316	6313	538	250SC
139	24.0	92	1373	746	28.5	55	110	---	80	16	49.0	59.0	M20X40	6313C3	6313C3	527	250MA
139	24.0	92	1403	746	28.5	75	140	---	110	20	67.5	79.5	M20X40	NU316	6313	540	250MC
91	24.0	---	1382	714	---	55	110	104	80	16	49.0	59.0	---	6314C3	6314C3	860	280SA
91	24.0	---	1442	714	---	85	170	157	140	22	76.0	90.0	---	NU320C3	6316	920/1000/1080	280SC
91	24.0	---	1432	713	---	55	110	104	80	16	49.0	59.0	---	6314C3	6314C3	905	280MA
91	24.0	---	1492	713	---	85	170	157	140	22	76.0	90.0	---	NU320C3	6316	990/1000/1010	280MC
126	28.0	---	1471	739	---	55	110	104	80	16	49.0	59.0	---	6314C3	6314C3	1020	315SA
126	28.0	---	1531	739	---	95	170	157	140	25	86.0	100.0	---	NU320C3	6316	1150/1140/1130	315SA
126	28.0	---	1522	739	---	55	110	104	80	16	49.0	59.0	---	6314C3	6314C3	1180	315MA
126	28.0	---	1582	739	---	95	170	157	140	25	86.0	100.0	---	NU320C3	6316	1240/1270/1300	315MC

EVVFG-S 外型尺寸圖立式

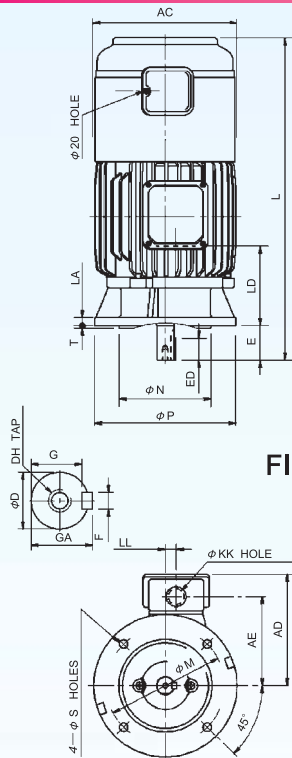

FIG.1

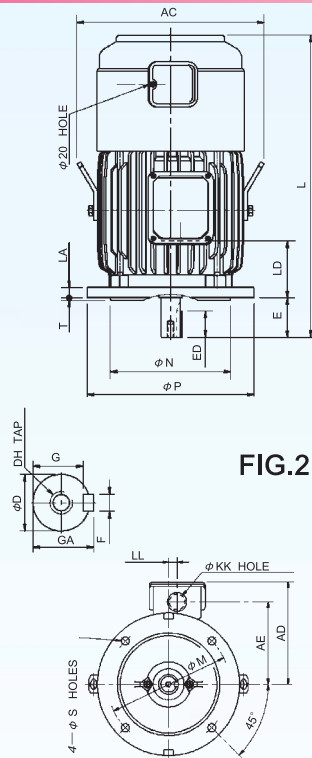

FIG.2

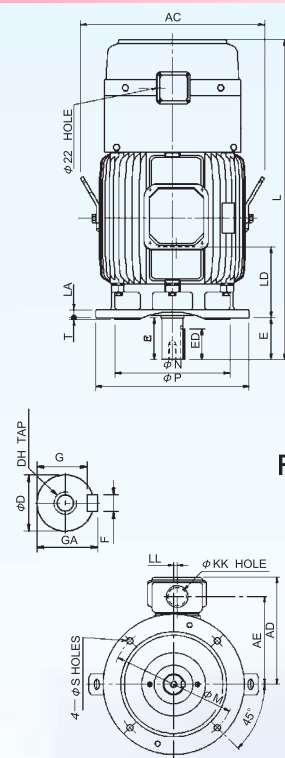

FIG.3

輸出馬力 (HP)				框號	圖號	AC	AD	AE	KK	L	LA	LD	LL	M	N	P
2P	4P	6P	8P													
0.5	0.5	---	---	71	1	164	145	103	22	372	12	82	17	130	110	160
1	1	0.5	---	80	1	179	152	112	22	373	12	60	15	165	130	200
2	2	1	---	90L	1	200	163	125	22	466	12	113	15	165	130	200
3	3	2	---	100L	2	280	180	145	28	461	16	88	15	215	180	250
5	5	3	---	112M	2	299	189	154	28	533	16	135	15	215	180	250
7.5	7.5	5	---	132S	2	337	224	180	35	538	20	97	13	265	230	300
10	10	7.5	---	132M	2	337	224	180	35	576	20	116	13	265	230	300
15	15	10	---	160M	3	434	263	218	35	743	20	151	10	300	250	350
20	20	15	---	160L	3	434	263	218	35	787	20	173	10	300	250	350
25	20	15	---	180MA	3	482	305	250	52	800	20	170	10	350	300	400
30	---	---	---	180MC	3	482	305	250	52	800	20	170	10	350	300	400
---	25	20	---	180LA	3	482	305	250	52	838	20	189	10	350	300	400
---	30	20	---	180LC	3	482	305	250	52	838	20	189	10	350	300	400
---	40	25	---	200LA	4	520	362	299	65	863	20	194	20	400	350	450
50	---	---	---	200LC	4	520	362	299	65	893	20	194	20	400	350	450
60	50	40	25	225SA	4	572	411	337	92	1020	22	190	30	500	450	550
---	60	50	30	225SC	4	572	411	337	92	1050	22	190	30	500	450	550
75	---	---	---	250SA	4	624	499	384	92	1115	22	201	30	500	450	550
---	75	60	40	250SC	4	624	499	384	92	1145	22	201	30	500	450	550
100	---	---	---	250MA	4	624	499	384	92	1172	22	230	30	500	450	550
---	100	75	50	250MC	4	624	499	384	92	1202	22	230	30	500	450	550
125	---	---	---	280SA	5	617	610	455	---	1382	25	156	30	600	550	660
---	125	100	60	280SC	5	617	610	455	---	1442	25	156	30	600	550	660
150	---	---	---	280MA	5	617	610	455	---	1471	25	200	30	600	550	660
---	150	125	75	280MC	5	617	610	455	---	1531	25	200	30	600	550	660

強冷式 變頻馬達 EVEF EVVF 系列

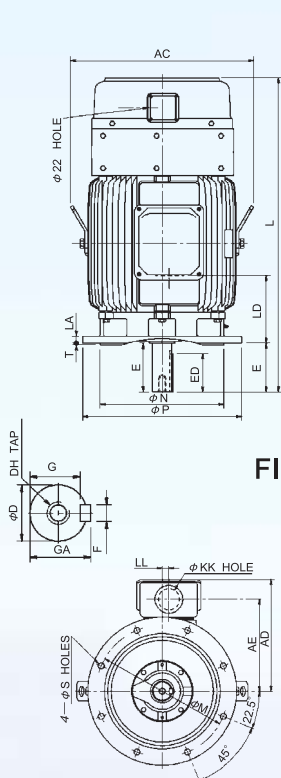

FIG.4

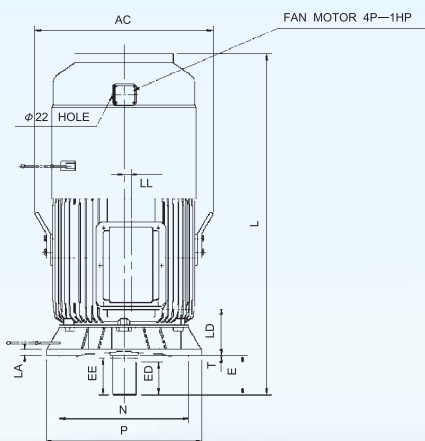
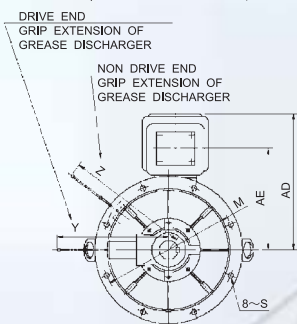

FIG.5



- 註：1. 軸心直徑D公差： $\phi 14-\phi 28$ ：j6， $\phi 38-\phi 48$ ：k6， $\phi 55-\phi 85$ ：m6。
2. 凸緣裝配引導徑N公差：h7。
3. 以上數值如有變更，恕不另行通知。

Dimension in mm

S	T	Y	Z	軸 端								軸 承		概略重量 Kgs	框號
				D	E	EE	ED	F	G	GA	DH	負載側	非負載側		
10.0	3.5	---	---	14	30	---	24	5	11.0	16.0	M5X10	6202ZZ	6202ZZ	15	71
12.0	3.5	---	---	19	40	---	25	6	15.5	21.5	M6X12	6204ZZ	6204ZZ	17	80
12.0	3.5	---	---	24	50	---	32	8	20.0	27.0	M8X16	6205ZZ	6205ZZ	29	90L
14.5	4.0	---	---	28	60	---	40	8	24.0	31.0	M10X20	6206ZZ	6305ZZ	36	100L
14.5	4.0	---	---	28	60	---	40	8	24.0	31.0	M10X20	6306ZZ	6306ZZ	48	112M
14.5	4.0	---	---	38	80	---	64	10	33.0	41.0	M12X24	6308ZZ	6306ZZ	75	132S
14.5	4.0	---	---	38	80	---	64	10	33.0	41.0	M12X24	6308ZZ	6306ZZ	86	132M
18.5	5.0	---	---	42	110	---	80	12	37.0	45.0	M16X32	6309ZZ	6307ZZ	134	160M
18.5	5.0	---	---	42	110	---	80	12	37.0	45.0	M16X32	6309ZZ	6307ZZ	156	160L
18.5	5.0	---	---	48	110	---	80	14	42.5	51.5	M16X32	6311ZZC3	6310ZZC3	199	180MA
18.5	5.0	---	---	48	110	---	80	14	42.5	51.5	M16X32	6311ZZ	6310ZZ	195	180MC
18.5	5.0	---	---	55	110	---	80	16	49.0	59.0	M20X40	6312ZZC3	6310ZZC3	227	180LA
18.5	5.0	---	---	55	110	---	80	16	49.0	59.0	M20X40	6312ZZ	6310ZZ	229	180LC
18.5	5.0	---	---	55	110	---	80	16	49.0	59.0	M20X40	6312C3	6212ZZC3	302	200LA
18.5	5.0	---	---	60	140	---	110	18	53.0	64.0	M20X40	6314	6212ZZC3	334	200LC
18.5	5.0	---	---	55	110	---	80	16	49.0	59.0	M20X40	6312C3	6212ZZC3	373	225SA
18.5	5.0	---	---	65	140	---	110	18	58.0	69.0	M20X40	6315	6213ZZ	401	225SC
18.5	5.0	---	---	55	110	---	80	16	49.0	59.0	M20X40	6313C3	6313C3	538	250SA
18.5	5.0	---	---	75	140	---	110	20	67.5	79.5	M20X40	NU316	6313	552	250SC
18.5	5.0	---	---	55	110	---	80	16	49.0	59.0	M20X40	6313C3	6313C3	541	250MA
18.5	5.0	---	---	75	140	---	110	20	67.5	79.5	M20X40	NU316	6313	554	250MC
24.0	6.0	585	585	55	110	104	80	16	49.0	59.0	---	6314C3	6314C3	850	280SA
24.0	6.0	560	555	85	170	157	140	22	76.0	90.0	---	NU320C3	6316	910/930/950	280SC
24.0	6.0	585	585	55	110	104	80	16	49.0	59.0	---	6314C3	6314C3	895	280MA
24.0	6.0	560	555	85	170	157	140	22	76.0	90.0	---	NU320C3	6316	1140/1130/1120	280MC

EVVYH-S 外型尺寸圖 (附P.G.)

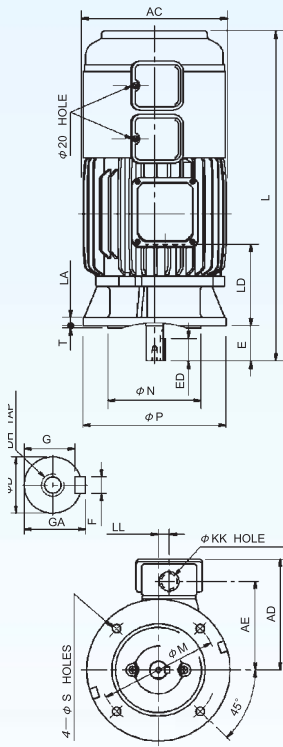

FIG.1

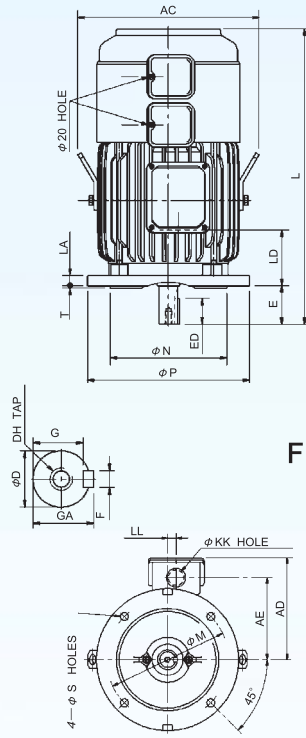

FIG.2

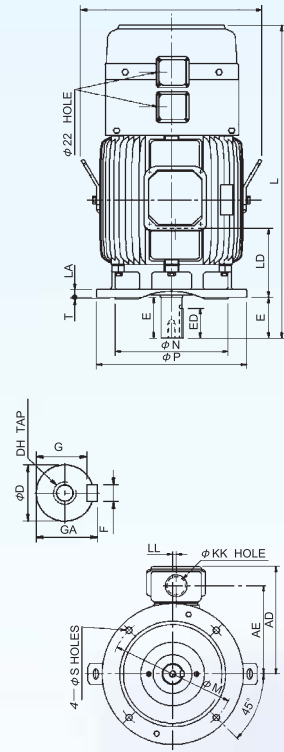

FIG.3

輸出馬力 (HP)				框號	圖號	AC	AD	AE	KK	L	LA	LD	LL	M	N	P
2P	4P	6P	8P													
0.5	0.5	---	---	71	1	164	145	103	22	372	12	82	17	130	110	160
1	1	0.5	---	80	1	179	152	112	22	373	12	60	15	165	130	200
2	2	1	---	90L	1	200	163	125	22	466	12	113	15	165	130	200
3	3	2	---	100L	2	280	180	145	28	461	16	88	15	215	180	250
5	5	3	---	112M	2	299	189	154	28	533	16	135	15	215	180	250
7.5	7.5	5	---	132S	2	337	224	180	35	538	20	97	13	265	230	300
10	10	7.5	---	132M	2	337	224	180	35	576	20	116	13	265	230	300
15	15	10	---	160M	3	434	263	218	35	743	20	151	10	300	250	350
20	20	15	---	160L	3	434	263	218	35	787	20	173	10	300	250	350
25	25	20	---	180MA	3	482	305	250	52	800	20	170	10	350	300	400
30	---	---	---	180MC	3	482	305	250	52	800	20	170	10	350	300	400
---	25	20	---	180LA	3	482	305	250	52	838	20	189	10	350	300	400
---	30	25	---	180LC	3	482	305	250	52	838	20	189	10	350	300	400
---	40	30	---	200LA	4	520	342	279	65	983	20	194	20	400	350	450
50	---	---	---	200LC	4	520	342	279	65	1013	20	194	20	400	350	450
60	50	40	25	225SA	4	572	386	312	92	1210	22	190	30	500	450	550
---	60	50	30	225SC	4	572	386	312	92	1240	22	190	30	500	450	550
75	---	---	---	250SA	4	624	499	384	92	1316	22	201	30	500	450	550
---	75	60	40	250SC	4	624	499	384	92	1346	22	201	30	500	450	550
100	---	---	---	250MA	4	624	499	384	92	1373	22	230	30	500	450	550
---	100	75	50	250MC	4	624	499	384	92	1403	22	230	30	500	450	550
125	---	---	---	280SA	5	617	610	455	---	1382	25	156	30	600	550	660
---	125	100	60	280SC	5	617	610	455	---	1442	25	156	30	600	550	660
150	---	---	---	280MA	5	617	610	455	---	1471	25	200	30	600	550	660
---	150	125	75	280MC	5	617	610	455	---	1531	25	200	30	600	550	660

強冷式 變頻馬達

EVEF EVVF 系列

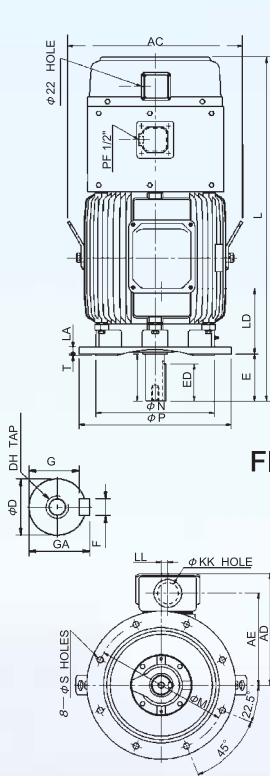

FIG.4

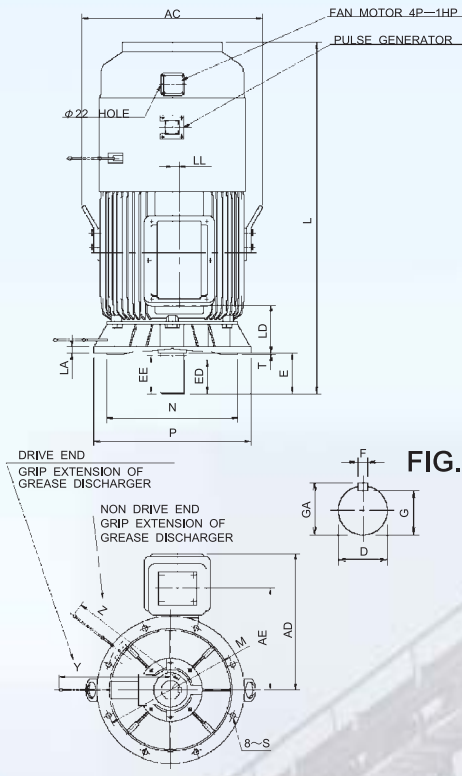

FIG.5



註：1. 軸心直徑D公差：

φ 14- φ 28 : j6 ,

φ 38- φ 48 : k6 ,

φ 55- φ 85 : m6 .

2. 凸緣裝配引導徑N公差：h7 .

3. 以上數值如有變更，恕不另行通知。

Dimension in mm

S	T	Y	Z	軸 端								軸 承		概略重量 Kgs	框號
				D	E	EE	ED	F	G	GA	DH	負載側	非負載側		
10.0	3.5	---	---	14	30	---	24	5	11.0	16.0	M5X10	6202ZZ	6202ZZ	15	71
12.0	3.5	---	---	19	40	---	25	6	15.5	21.5	M6X12	6204ZZ	6204ZZ	18	80
12.0	3.5	---	---	24	50	---	32	8	20.0	27.0	M8X16	6205ZZ	6205ZZ	29	90L
14.5	4.0	---	---	28	60	---	40	8	24.0	31.0	M10X20	6206ZZ	6305ZZ	37	100L
14.5	4.0	---	---	28	60	---	40	8	24.0	31.0	M10X20	6306ZZ	6306ZZ	49	112M
14.5	4.0	---	---	38	80	---	64	10	33.0	41.0	M12X24	6308ZZ	6306ZZ	76	132S
14.5	4.0	---	---	38	80	---	64	10	33.0	41.0	M12X24	6308ZZ	6306ZZ	87	132M
18.5	5.0	---	---	42	110	---	80	12	37.0	45.0	M16X32	6309ZZ	6307ZZ	134	160M
18.5	5.0	---	---	42	110	---	80	12	37.0	45.0	M16X32	6309ZZ	6307ZZ	156	160L
18.5	5.0	---	---	48	110	---	80	14	42.5	51.5	M16X32	6311ZZC3	6310ZZC3	199	180MA
18.5	5.0	---	---	48	110	---	80	14	42.5	51.5	M16X32	6311ZZ	6310ZZ	196	180MC
18.5	5.0	---	---	55	110	---	80	16	49.0	59.0	M20X40	6312ZZC3	6310ZZC3	227	180LA
18.5	5.0	---	---	55	110	---	80	16	49.0	59.0	M20X40	6312ZZ	6310ZZ	229	180LC
18.5	5.0	---	---	55	110	---	80	16	49.0	59.0	M20X40	6312C3	6212ZZC3	305	200LA
18.5	5.0	---	---	60	140	---	110	18	53.0	64.0	M20X40	6314	6212ZZC3	337	200LC
18.5	5.0	---	---	55	110	---	80	16	49.0	59.0	M20X40	6312C3	6212ZZC3	379	225SA
18.5	5.0	---	---	65	140	---	110	18	58.0	69.0	M20X40	6315	6213ZZ	406	225SC
18.5	5.0	---	---	55	110	---	80	16	49.0	59.0	M20X40	6313C3	6313C3	545	250SA
18.5	5.0	---	---	75	140	---	110	20	67.5	79.5	M20X40	NU316	6313	559	250SC
18.5	5.0	---	---	55	110	---	80	16	49.0	59.0	M20X40	6313C3	6313C3	546	250MA
18.5	5.0	---	---	75	140	---	110	20	67.5	79.5	M20X40	NU316	6313	559	250MC
24.0	6.0	585	585	55	110	104	80	16	49.0	59.0	---	6314C3	6314C3	860	280SA
24.0	6.0	560	555	85	170	157	140	22	76.0	90.0	---	NU320C3	6316	920/940/960	280SC
24.0	6.0	585	585	55	110	104	80	16	49.0	59.0	---	6314C3	6314C3	905	280MA
24.0	6.0	560	555	85	170	157	140	22	76.0	90.0	---	NU320C3	6316	1150/1140/1130	280MC

■編碼器P.G.接線圖



■P.G.輸出介面電路

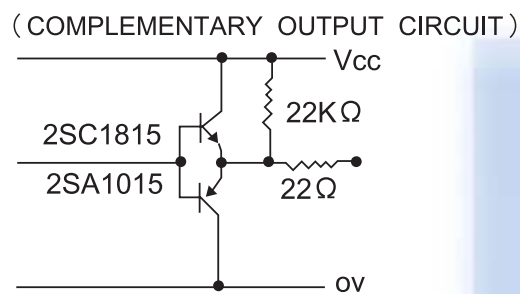

TECO 東元電機股份有限公司

重電營業處：台北市南港區園區街3之1號10樓
 TEL:(02)6615-9111 FAX:(02)6616-2503 <http://www.tecomotor.com.tw>

經銷商：