



CDL 50Hz

Light Vertical Multistage Centrifugal Pump

CDLF



Hangzhou Nanfang
Special Pump Industry Co.,Ltd.

Worldwide CNP Sales & Service Network
CNP Headquarter
Address: Renhe Town, Yuhang District, Hangzhou, Zhejiang
Tel: +86 571 86397810 , 86397838
Fax: +86 571 86397809
PostCode: 311107
E-mail: info@nanfang-pump.com
Website: <http://www.nanfang-pump.com>



E090803

The technical data are subject to amend without notice.

Company Profile



Hangzhou Nanfang Special Pump Industry Co.,Ltd. is specialized in manufacture of stainless steel multistage pumps, integrating scientific research, production and marketing. Since its establishment nearly 20 years ago, the company has devoted considerable efforts to innovation and management. The company has successfully developed various kinds of pumps which are applicable to industrial and mining enterprises, municipal water supply, farm irrigation, petrochemical engineering, domestic water and fire fighting water supply of high buildings, industrial water treatment, water purification, pharmaceutical industry, boiler, air-conditioning system etc. The main performances of CDL series stainless steel multistage vertical pump, TD in-line circulation pump, SJ series stainless steel multistage deep-well submersible pump, CDLK, CDLKF immersion type multi-stage centrifugal pump, CHL/CHLK/CHLF series stainless steel multistage horizontal pumps and QY series stainless steel pump conveying mixed gas and liquid, ZS series stainless steel horizontal single-stage centrifugal pump, MS series light stainless steel horizontal single-stage centrifugal pump, have fully reached international advanced level.

Besides designing pumps with advanced tools such as three-dimensional CAD and CFD software, the company boasts a complete set of precision manufacturing and inspection equipment. With perfect quality control system, the company has passed ISO9001 Quality System Certification, ISO14001 Environment Management System Certificate, and obtained CE Mark also. The company sell products well not only at home, but also in foreign countries, Europe, America, Southeastern Asia etc, gaining popularity due to their excellent quality, good credit standing and considerate after-sales service.

The company has established a wide sales and service network which has representative offices and service centers. Offices and service centers are set in all large and medium-scale cities, aiming to providing timely and satisfactory service for customers.

Satisfying customers will be eternal pursuit of the company. Looking forward to the future, the company will further keep up its fine tradition and persist in its business principle of "quality first, credit first and clients first" to offer customers products of high quality and more considerate services.

Nanfang pump, an international brand worthy of your trust!

Content

General Data

- Performance scope ----- 3
- Product range ----- 3
- Pump ----- 4
- Max. working pressure ----- 5
- Max. Ambient temperature ----- 5
- Curve illustration ----- 6
- Performance curve ----- 6
- Min. Inlet pressure NPSH ----- 7
- Operation in parallel ----- 7
- Material ----- 8

Technical Data

- CDL/CDLF1,50Hz ----- 12
- CDL/CDLF2,50Hz ----- 14
- CDL/CDLF3,50Hz ----- 16
- CDL/CDLF4,50Hz ----- 18
- CDL/CDLF8,50Hz ----- 20
- CDL/CDLF12,50Hz ----- 22
- CDL/CDLF16,50Hz ----- 24
- CDL/CDLF20,50Hz ----- 26
- CDL/CDLF32,50Hz ----- 28
- CDL/CDLF42,50Hz ----- 30
- CDL/CDLF65,50Hz ----- 32
- CDL/CDLF85,50Hz ----- 34
- CDL/CDLF120,50Hz ----- 36
- CDL/CDLF150,50Hz ----- 38

Performance scope

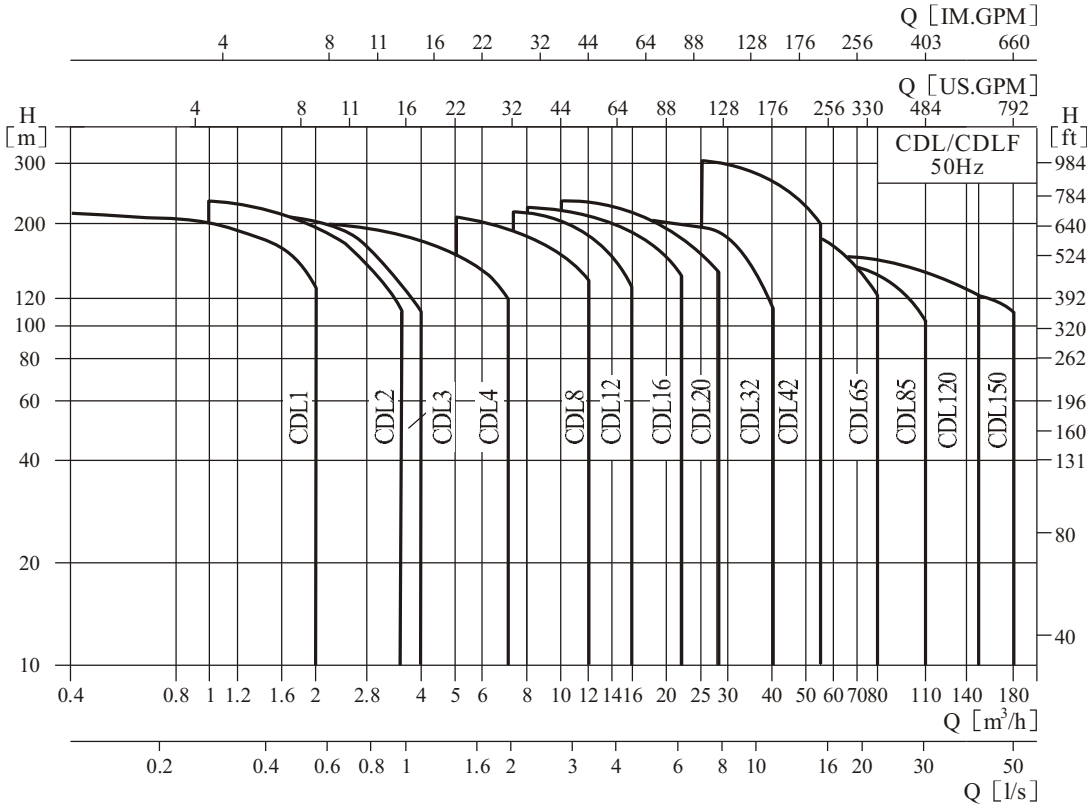

Product range

Description	CDL1	CDL2	CDL3	CDL4	CDL8	CDL12	CDL16	CDL20	CDL32	CDL42	CDL65	CDL85	CDL120	CDL150
Rated flow [m³/h]	1	2	3	4	8	12	16	20	32	42	65	85	120	150
Rated flow [l/s]	0.28	0.56	0.83	1.1	2.2	3.3	4.4	5.6	8.9	11.7	18	24	33	41.6
Flow range [m³/h]	0.4-2	1-3.5	1.2-4	1.5-7	5-12	7-16	8-22	10-28	16-40	25-55	30-80	50-110	60-150	80-180
Flow range [l/s]	0.11-0.56	0.28-0.97	0.33-1.1	0.42-1.9	1.4-3.3	1.9-4.4	2.2-6.1	2.8-7.8	4.4-11.1	6.9-15.3	8.3-22.2	13.8-30.5	16.7-41.7	22-50
Max.pressure [bar]	21	23	22	21	21	22	22	23	26	30	22	17	16	16
Motor power [kW]	0.37-2.2	0.37-3	0.37-3	0.37-4	0.75-7.5	1.5-11	2.2-15	1.1-18.5	1.5-30	3.0-45	4.0-45	5.5-45	11-75	11-75
Temperature range [°C]	-15~+120													
Max. efficiency [%]	44	46	54	59	64	63	66	69	76	78	80	81	74	73
Type														
CDL	●	●	●	●	●	●	●	●	●	●	●	●	●	●
CDLF	●	●	●	●	●	●	●	●	●	●	●	●	●	●
CDL Pipe connection														
DIN Flange	DN25	DN25	DN25	DN32	DN40	DN50	DN50	DN50	DN50	DN65	DN80	DN100	DN100	DN125
Oval Flange	G1	G1	G1	G1¼	G1½									
CDLF Pipe connection														
DIN Flange	DN25	DN 5	DN25	DN 32	DN40	DN50	DN50	DN50	DN65	DN80	DN100	DN100	DN125	DN125
Cutting ferrule joint	●	●	●	●	●	●	●	●						
Pipe thread	●	●	●	●	●	●	●	●						

● Pump

CDL / CDLF is a kind of vertical non-self priming multistage centrifugal pump, which is driven by a standard electric motor. The motor output shaft directly connects with the pump shaft through a coupling. The pressure-resistant cylinder and flow passage components are fixed between pump head and inlet & outlet section with stay bolts. The inlet and outlet are located at the pump bottom at the same plane. This kind of pump can be equipped with an intelligent protector to effectively prevent it from dry-running, out-of-phase and overload.

● Motor

- Full-enclosed air-blast two-pole standard motor
- Protection class: IP55
- Insulation class: F
- Standard voltage: 50Hz: 1 × 220-230 / 240V
3 × 200-220 / 346-380V
3 × 220-240 / 380-415V
3 × 380-415V

● Definition of Model

CDL/CDLF1,2,3,4,8,12,16 and 20

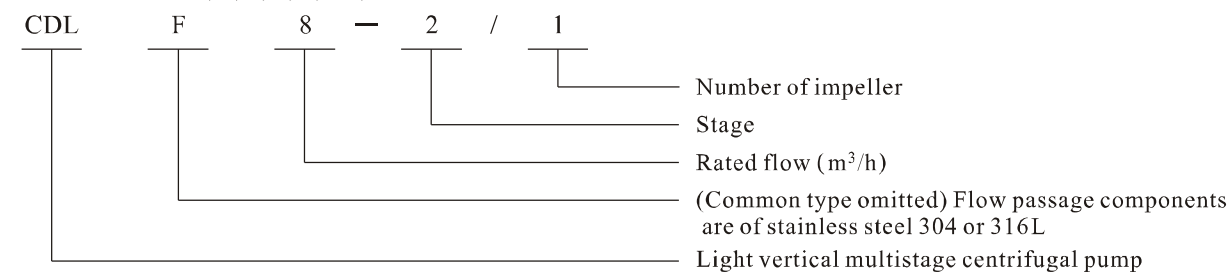

CDL/CDLF32,42,65,85,120 and 150

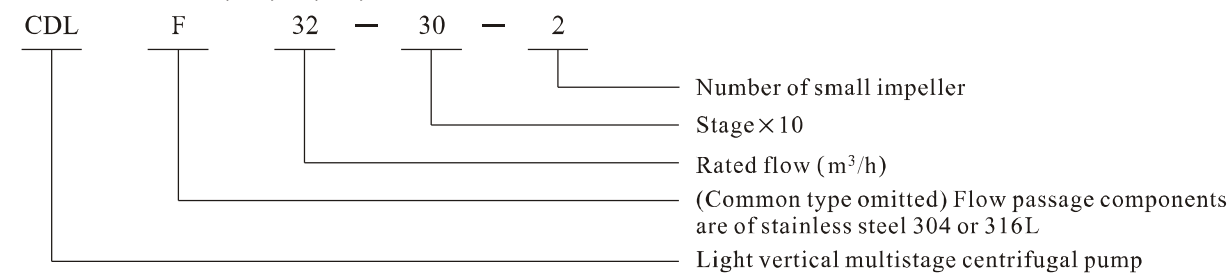

● Application

CDL / CDLF is a kind of multifunctional products. It can be used to convey various medium from tap water to industrial liquid at different temperature and with different flow rate and pressure. CDL type is applicable to conveying non-corrosive liquid, while CDLF is suitable for slightly corrosive liquid.

- Water supply: Water filter and transport in Waterworks, boosting of main pipeline, boosting in high-rise buildings.
- Industrial boosting: Process flow water system, cleaning system, high-pressure washing system, fire fighting system.
- Industrial liquid conveying: Cooling and air-conditioning system, boiler water supply and condensing system, machine-associated purpose, acids and alkali.
- Water treatment: Ultrafiltration system, reverse osmosis system, distillation system, separator, swimming pool.
- Irrigation: Farmland irrigation, spray irrigation, dripping irrigation.

● Operation conditions

- Thin, clean, non-flammable and non-explosive liquid containing no solid granules and fibers.
- Liquid temperature:
Normal temperature type: -15°C ~ +70°C,
Hot water type: +70°C ~ +120°C
- Ambient temperature: up to +40°C
- Altitude: up to 1000m

● Max. Working pressure

Model	Curve number
CDL,CDLF1	
1-2~1-23	1
1-25~1-36	2
CDL,CDLF2	
2-2-15	1
2-18~2-26	2
CDL,CDLF3	
3-2~3-23	1
3-25~3-36	2
CDL,CDLF4	
4-2~4-16	1
4-19~4-22	2
CDL,CDLF8	
8-2/1~8-12	1
8-14~8-20	3
CDL,CDLF12	
12-2~12-10	1
12-12~12-18	3
CDL,CDLF16	
16-2~16-8	1
16-10~16-16	3
CDL,CDLF20	
20-1~20-8	1
20-10~20-17	3
CDL,CDLF32	
32-10-1~32-70	1
32-80-2~32-120	4
32-130~32-140	5
CDL,CDLF42	
42-10-1~42-60	1
42-70-2~42-90	4
42-100-2~42-130-2	5
CDL,CDLF65	
65-10-1~65-50	1
65-60-2~65-80-1	4
CDL,CDLF85	
85-10-1~85-50-2	1
85-50~85-60	4
CDL,CDLF120,150	6

The following figure shows the limitation of pressure and temperature, which shall be in the scope as shown in the figure.

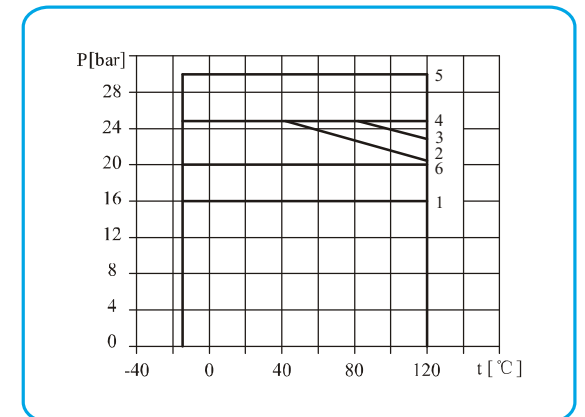

Max. Ambient temperature

When the pump operates under ambient temperature higher than 40°C or under altitude higher than 1000m, because of low air density and poor cooling effects, the motor output power P2 will be decreased to certain extent. If the pump is operated under the above-said conditions, it should be equipped with motor of higher power.

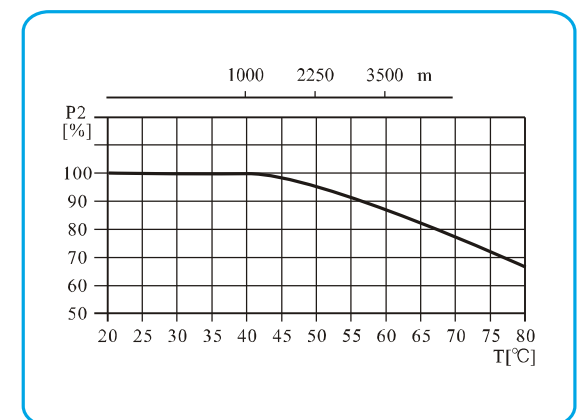

● Curve illustration

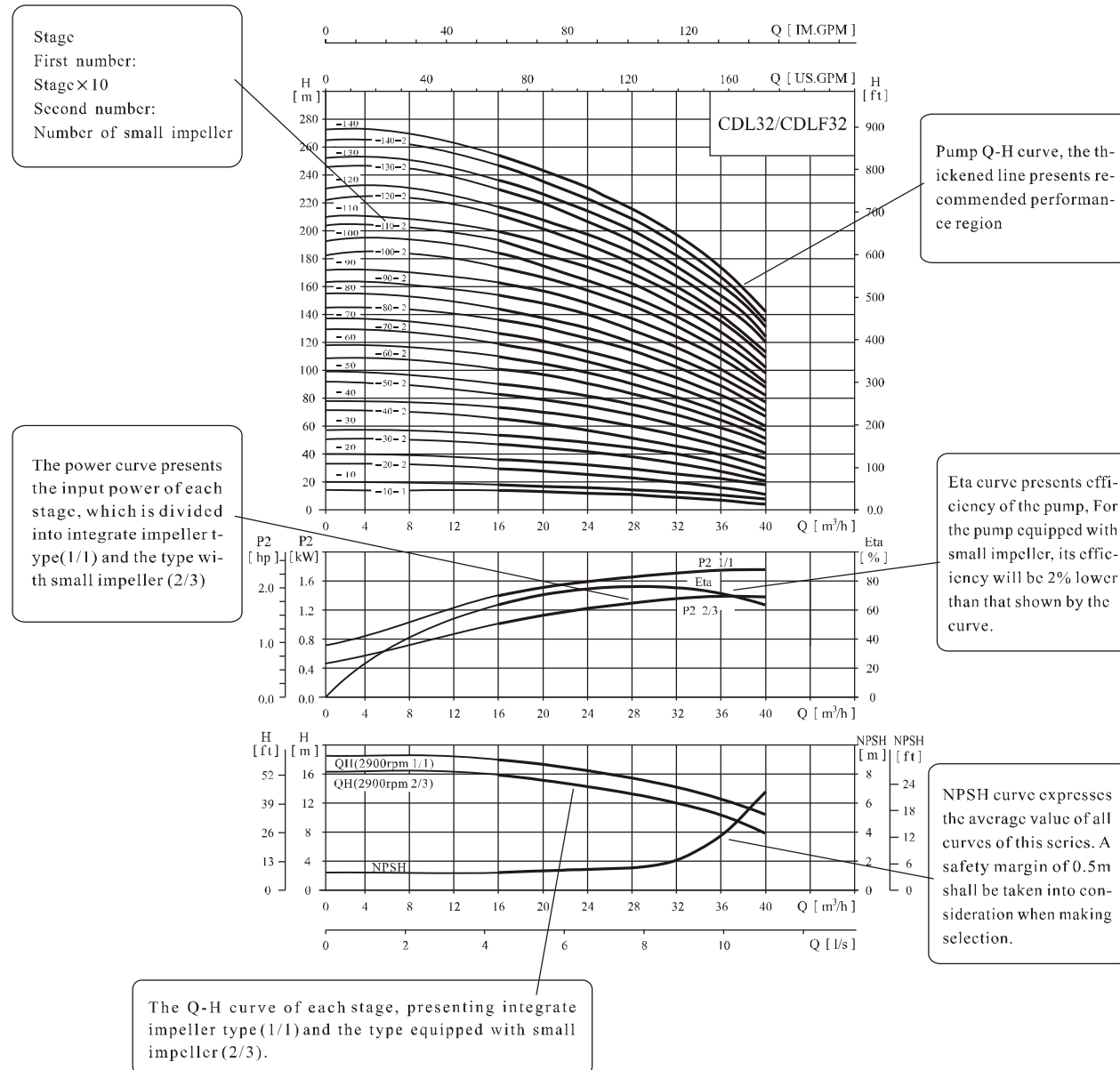

● Performance curve

Following conditions are suitable for the performance curves shown below:

- 1、 All curves are based on the measured values of 50Hz: constant motor speed 2900rpm or 2950rpm.
- 2、 Curve tolerance in conformity with ISO9906 Annex A.

matic viscosity of 1mm²/sec.

- 4、 The operation of pump shall refer to the performance region indicated by the thickened curve to prevent overheating due to too small flow rate or overload of motor due to too large flow rate.

● Minimum inlet pressure NPSH

In case that the pressure in pump is lower than the steam pressure used to convey liquid, the cavitations will occur. To avoid cavitations, a minimum pressure at the inlet side of the pump shall be guaranteed. The maximum suction stroke can be calculated with following formula:

$$H = P_b \times 10.2 - NPSH - H_f - H_v - H_s$$

P_b = atmosphere pressure [bar]

(can be set as 1 bar)

In a closed system, P_b means system pressure [bar]

NPSH = Net positive suction head [m]

(It can be read out from the point of possible max.

flow rate shown on NPSH curve)

H_f = Pipeline loss at the inlet [m]

H_v = Steam pressure [m]

H_s = Safety margin = Minimum 0.5m delivery head

If the calculated result H is positive, the pump may run under the max. Suction stroke H.

In case the calculated result H is negative, a delivery head of min. Inlet pressure is necessary.

● Operation in parallel

Connecting several pumps in parallel running will benefit much more than running a single large pump.

- Applicable to different working states necessary in a variable flow system.

- Increasing the possibility of water supply when the pump is in failure. Because in case of pump failure, only part of the system flow is effected.

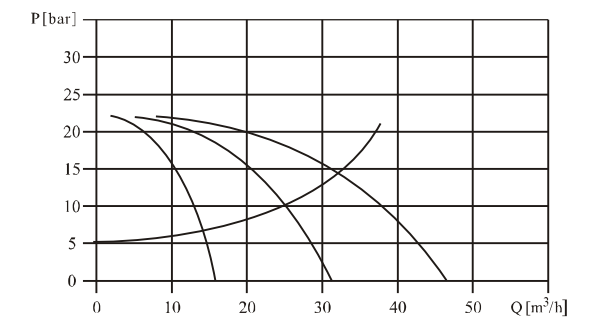

Two pumps or more can be connected in parallel running if necessary.

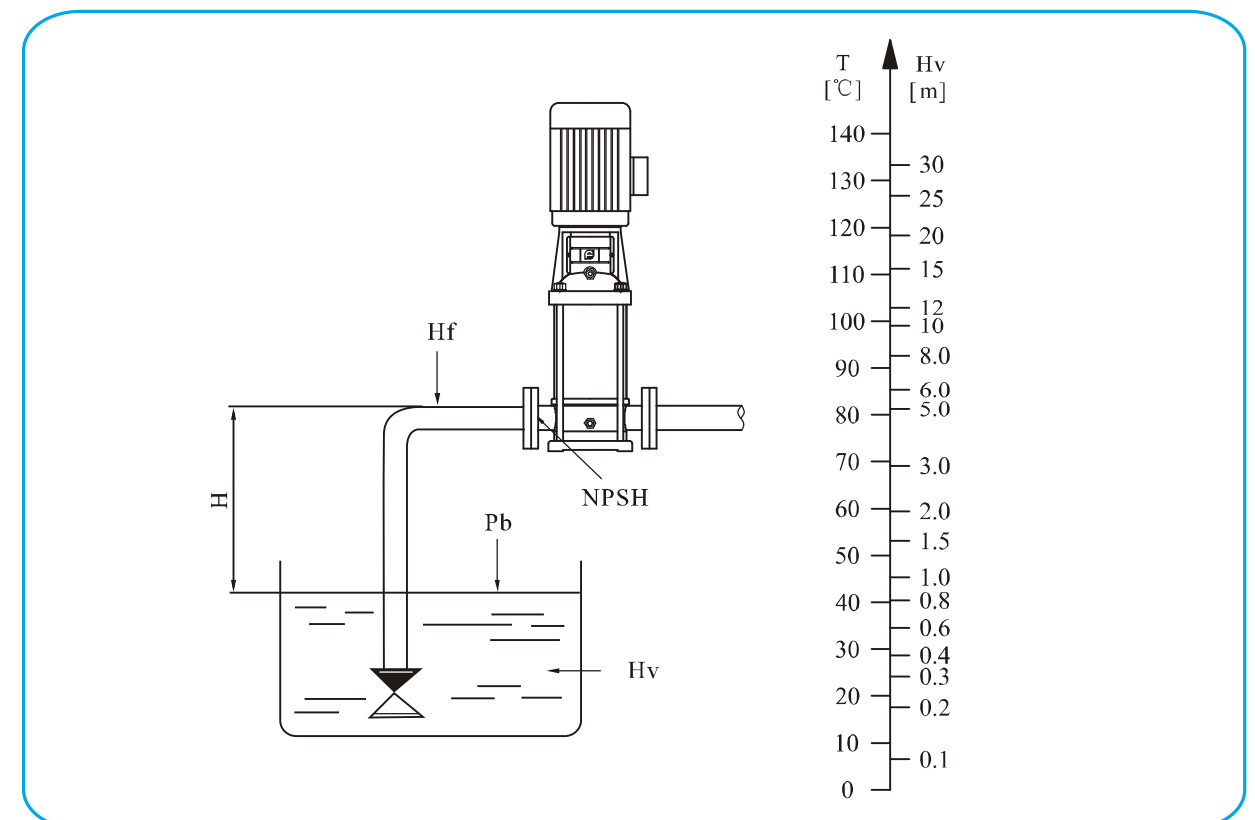

Check and ensure that the pump is not at cavitations state.

● Section drawing CDL/CDLF1,2,3,4

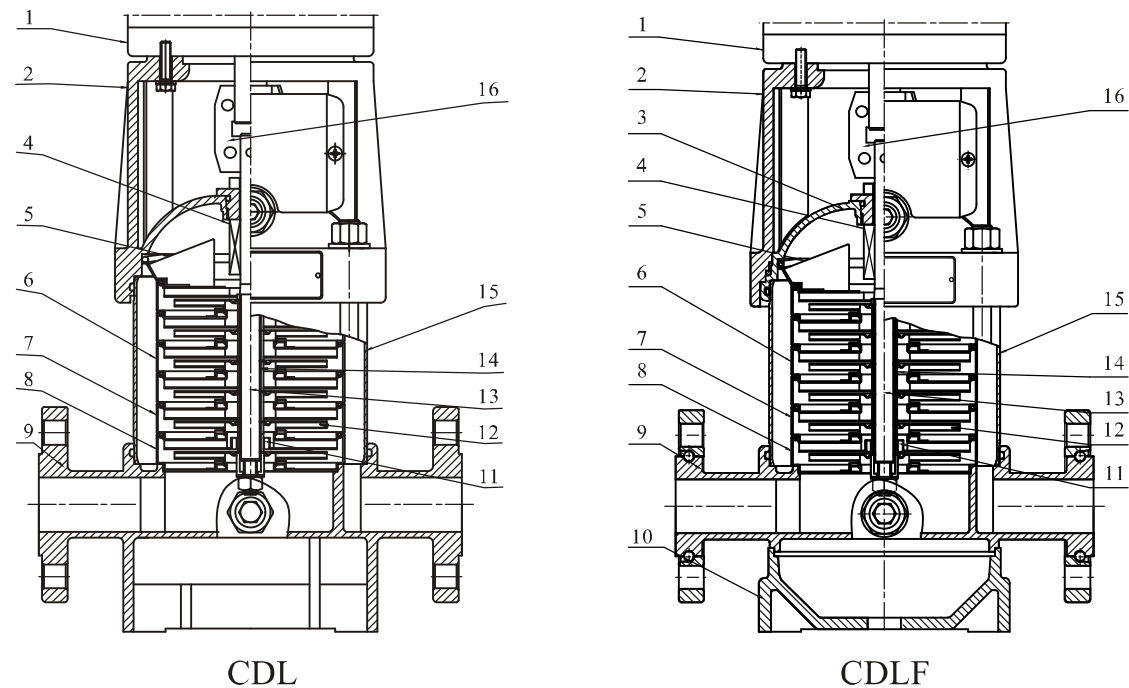

● Section drawing CDL/CDLF8,12,16,20

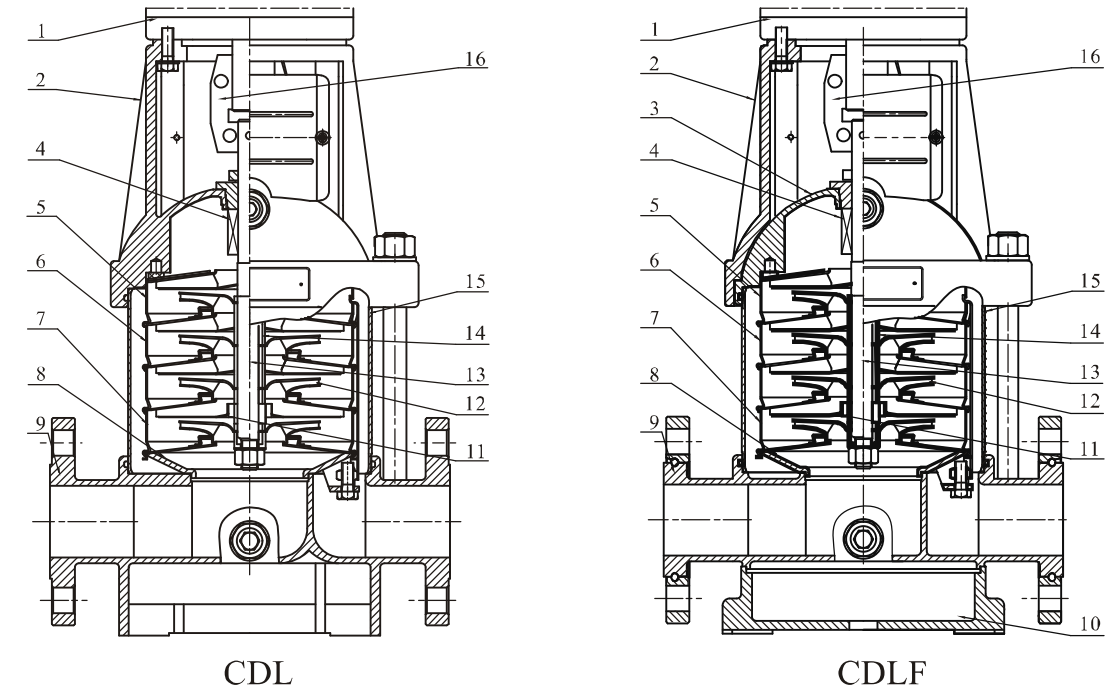

● Material CDL/CDLF1,2,3,4

NO.	Name	Material	AISI/ASTM
1	Motor		
2	Pump head	Cast iron	ASTM25B
4	Mechanical seal		
5	Top diffuser	Stainless steel	AISI304
6	Diffuser	Stainless steel	AISI304
7	Support diffuser	Stainless steel	AISI304
8	Inducer	Stainless steel	AISI304
11	Bearing	Tungsten carbide	
12	Impeller	Stainless steel	AISI304
13	Shaft	Stainless steel	AISI304 AISI316L

NO.	Name	Material	AISI/ASTM
14	Impeller sleeve	Stainless steel	AISI304
15	Cylinder	Stainless steel	AISI304
16	Coupling	Carbon steel	
CDLF			
3	Seal base	Stainless steel	AISI304
9	Inlet and outlet chamber	Stainless steel	AISI304
10	Base plate	Cast iron	ASTM25B
CDL			
9	Inlet and outlet chamber	Cast iron	ASTM25B

● Material CDL/CDLF8,12,16,20

NO.	Name	Material	AISI/ASTM
1	Motor		
2	Pump head	Cast iron	ASTM25B
4	Mechanical seal		
5	Top diffuser	Stainless steel	AISI304
6	Diffuser	Stainless steel	AISI304
7	Support diffuser	Stainless steel	AISI304
8	Inducer	Stainless steel	AISI304
11	Bearing	Tungsten carbide	
12	Impeller	Stainless steel	AISI304
13	Shaft	Stainless steel	AISI304 AISI316L

NO.	Name	Material	AISI/ASTM
14	Impeller sleeve	Stainless steel	AISI304
15	Cylinder	Stainless steel	AISI304
16	Coupling	Carbon steel	
CDLF			
3	Seal base	Stainless steel	AISI304
9	Inlet and outlet chamber	Stainless steel	AISI304
10	Base plate	Cast iron	ASTM25B
CDL			
9	Inlet and outlet chamber	Cast iron	ASTM25B

● Section drawing CDL/CDLF32,42,65,85

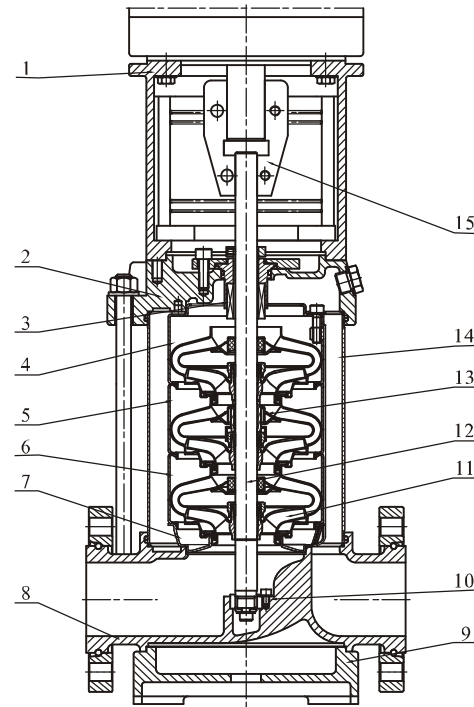

● Material CDL/CDLF32,42,65,85

NO.	Name	Material	AISI/ASTM	NO.	Name	Material	AISI/ASTM
1	Bracket	Cast iron	ASTM25B	12	Shaft	Stainless steel	AISI316L AISI304 AISI431
3	Mechanical seal			13	Intermediate bearing	Tungsten carbide	
4	Top diffuser	Stainless steel	AISI304	14	Cylinder	Stainless steel	AISI304
5	Support diffuser	Stainless steel	AISI304	15	Coupling	Carbon steel	
6	Diffuser	Stainless steel	AISI304		Rubber parts	NBR	
7	Inducer	Stainless steel	AISI304	CDL			
9	Base plate	Cast iron	ASTM25B	2	Pump head	Cast iron	ASTM25B
10	Bottom bearing	Tungsten carbide		8	Inlet and outlet chamber	Cast iron	ASTM25B
11	Impeller	Stainless steel	AISI304	CDLF			
				2	Pump head	Stainless steel	AISI304
				8	Inlet and outlet chamber	Stainless steel	AISI304

● Section drawing CDL/CDLF120,150

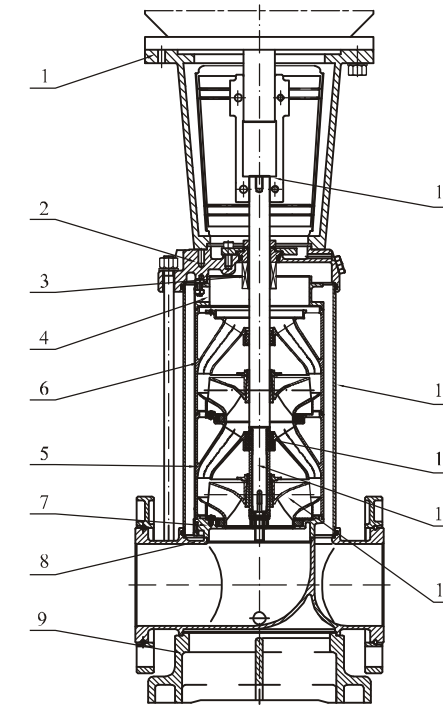

● Material CDL/CDLF120,150

NO.	Name	Material	AISI/ASTM	NO.	Name	Material	AISI/ASTM
1	Bracket	Cast iron	ASTM25B	13	Bearing	Tungsten carbide	
3	Mechanical seal			14	Cylinder	Stainless steel	AISI304
4	Discharge	Stainless steel	AISI304	15	Coupling	Carbon steel	
5	Support diffuser	Stainless steel	AISI304		Rubber parts	NBR	
6	Diffuser	Stainless steel	AISI304	CDL			
7	Inducer	Stainless steel	AISI304	2	Pump head	Cast iron	ASTM 80-55-06
9	Base plate	Cast iron	ASTM 80-55-06	8	Inlet and outlet chamber	Cast iron	ASTM 80-55-06
11	Impeller	Stainless steel	AISI304	CDLF			
12	Shaft	Stainless steel	AISI304	2	Pump head	Stainless steel	AISI304
				8	Inlet and outlet chamber	Stainless steel	AISI304

● Performance curve

ISO9906 Annex A 2900rpm

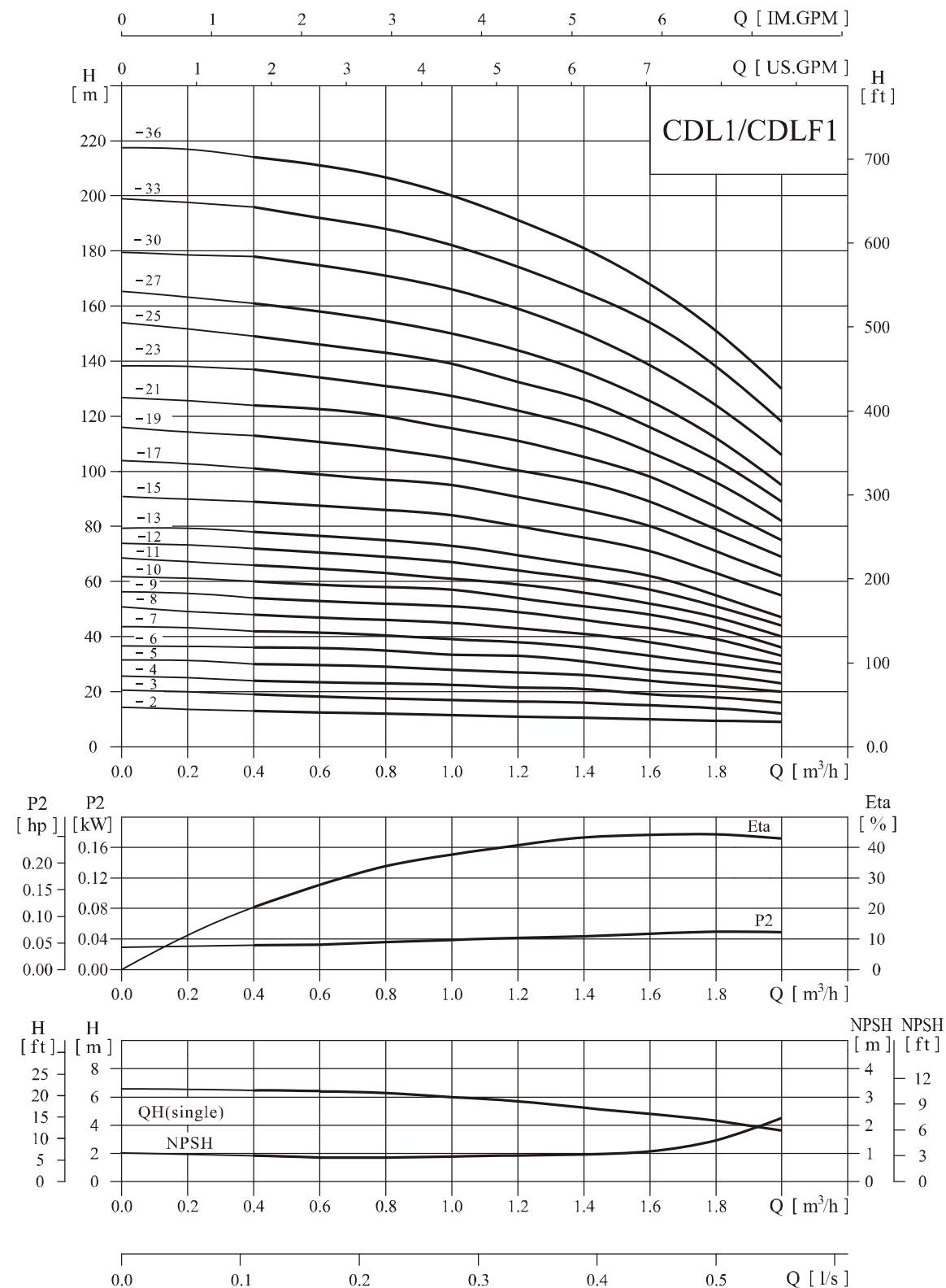

● Performance table

Model	Driving motor		Q (m³/h)	0.4	0.6	0.8	1.0	1.2	1.4	1.6	1.8	2.0
	(kW)	(hp)										
CDL1-2	0.37	0.5	13	12.5	12	11.5	11	10.5	10	9.5	9	9
CDL1-3	0.37	0.5	19	18	17.5	17	16.5	16	15	14	12	12
CDL1-4	0.37	0.5	24	23.5	23	22.5	21.5	21	19	18	16	16
CDL1-5	0.37	0.5	30	29.6	29	28	27	26	24	22	20	20
CDL1-6	0.37	0.5	36	35.5	35	33.5	33	31	28	26	23	23
CDL1-7	0.37	0.5	42	41	40.5	39	38	36	33	30	27	27
CDL1-8	0.55	0.75	48	47	46	45	43	41	38	34	30	30
CDL1-9	0.55	0.75	54	53	52	51	49	46	43	39	33	33
CDL1-10	0.55	0.75	60	59	58	57	54	51	48	43	36	36
CDL1-11	0.55	0.75	66	65	63	61	59	56	52	47	40	40
CDL1-12	0.75	1	72	71	69	67	64	61	57	51	44	44
CDL1-13	0.75	1	78	77	75	73	69	66	62	55	47	47
CDL1-15	0.75	1	89	88	86	84	79	76	71	63	55	55
CDL1-17	1.1	1.5	101	99	97	95	89	86	80	71	62	62
CDL1-19	1.1	1.5	113	110	108	106	99	96	89	79	69	69
CDL1-21	1.1	1.5	124	122	120	117	110	106	98	87	75	75
CDL1-23	1.1	1.5	137	133	131	128	121	116	107	96	82	82
CDL1-25	1.5	2	149	145	143	139	131	126	116	104	89	89
CDL1-27	1.5	2	161	157	155	150	141	136	125	112	95	95
CDL1-30	1.5	2	178	175	171	166	157	150	139	124	106	106
CDL1-33	2.2	3	196	192	188	183	173	165	154	137	118	118
CDL1-36	2.2	3	214	210	205	200	190	181	169	151	130	130

● Installation sketch

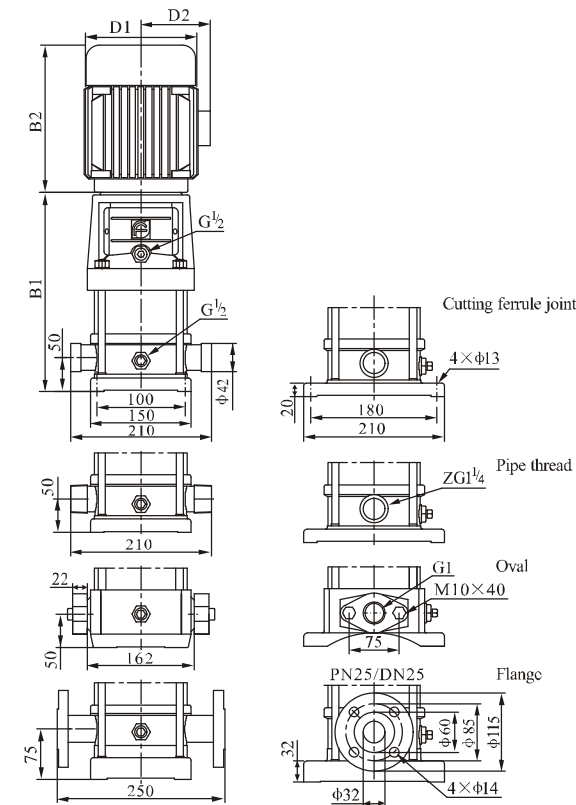

● Size and weight

Model	Size (mm)					Weight (kg)
	B1	B2	B1+B2	D1	D2	
CDL1-2	258	210	468	148	117	20
CDL1-3	276	210	486	148	117	20
CDL1-4	294	210	504	148	117	20
CDL1-5	312	210	522	148	117	20
CDL1-6	330	210	540	148	117	20
CDL1-7	348	210	558	148	117	20
CDL1-8	366	210	576	148	117	22
CDL1-9	384	210	594	148	117	22
CDL1-10	402	210	612	148	117	22
CDL1-11	420	210	630	148	117	22
CDL1-12	448	245	693	170	142	25
CDL1-13	466	245	711	170	142	25
CDL1-15	502	245	747	170	142	25
CDL1-17	538	245	783	170	142	28
CDL1-19	574	245	819	170	142	28
CDL1-21	610	245	855	170	142	30
CDL1-23	646	245	891	170	142	33
CDL1-25	692	290	982	190	155	40
CDL1-27	728	290	1018	190	155	40
CDL1-30	782	290	1072	190	155	40
CDL1-33	836	290	1126	190	155	45
CDL1-36	890	290	1180	190	155	45

CDL1-25 ~ 1-36 sub-connection of pipeline has no oval flange connection. The overall dimensions of the single-phase motor and explosion-proof motor are a little different. Pls contact us for details.

● Performance curve

ISO9906 Annex A 2900rpm

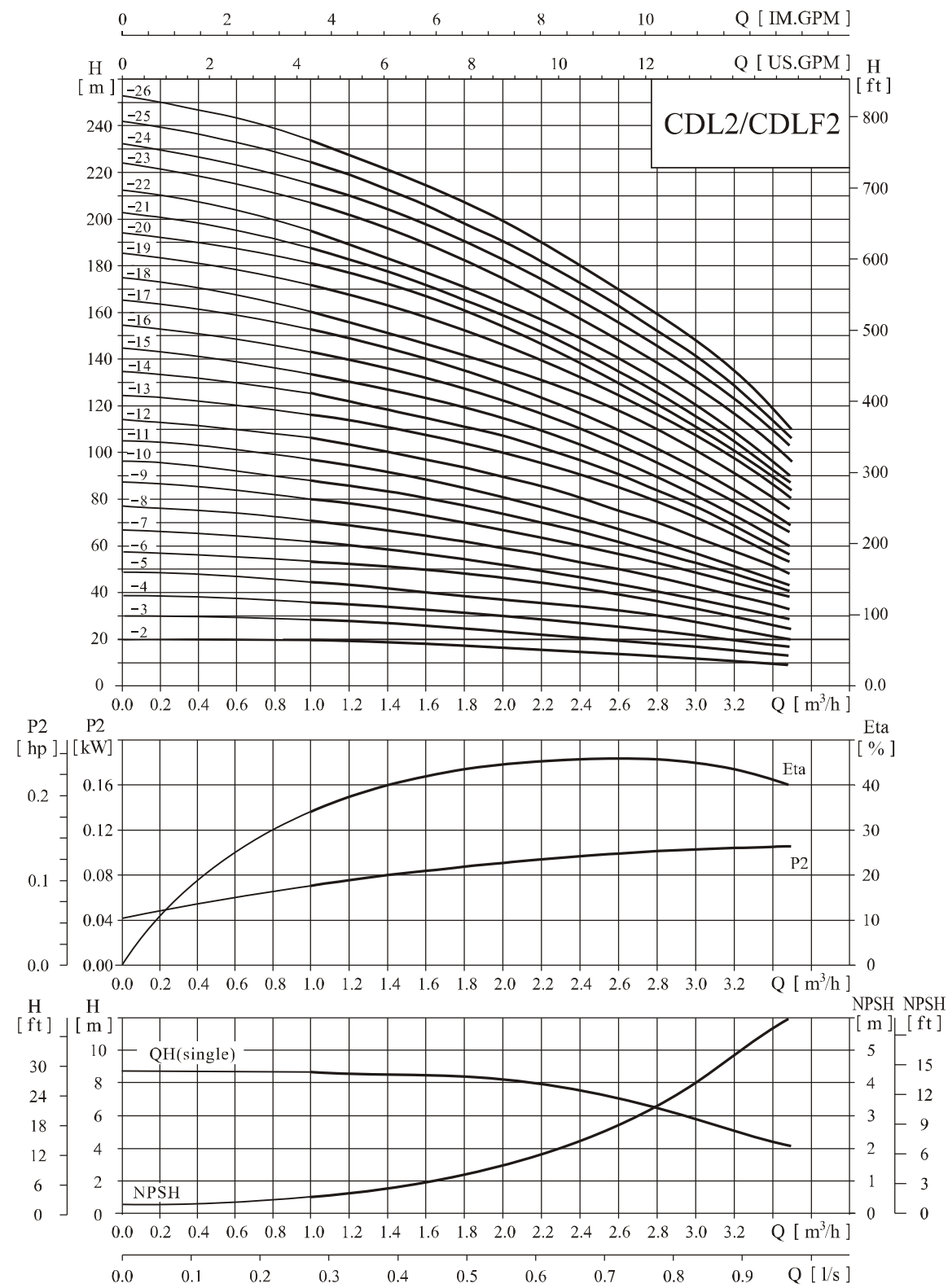

● Performance table

Model	Driving motor		Q (m³/h)	1	1.2	1.6	2.0	2.4	2.8	3.2	3.5
	(kW)	(hp)									
CDL2-2	0.37	0.5	H (m)	18	17	16	15	13	12	10	8
CDL2-3	0.37	0.5		27	26	24	22	20	18	15	12
CDL2-4	0.55	0.75		36	35	33	30	26	24	20	16
CDL2-5	0.55	0.75		45	43	40	37	33	30	24	20
CDL2-6	0.75	1		53	52	50	45	40	36	30	24
CDL2-7	0.75	1		63	61	57	52	47	41	35	28
CDL2-9	1.1	1.5		80	78	73	67	61	54	45	37
CDL2-11	1.1	1.5		98	95	89	82	73	64	54	44
CDL2-13	1.5	2		116	114	106	98	89	78	65	52
CDL2-15	1.5	2		134	130	123	112	100	90	73	60
CDL2-18	2.2	3		161	157	148	136	121	108	91	76
CDL2-22	2.2	3		197	192	180	165	148	130	110	90
CDL2-26	3.0	4		232	228	214	198	179	158	130	110

● Installation sketch

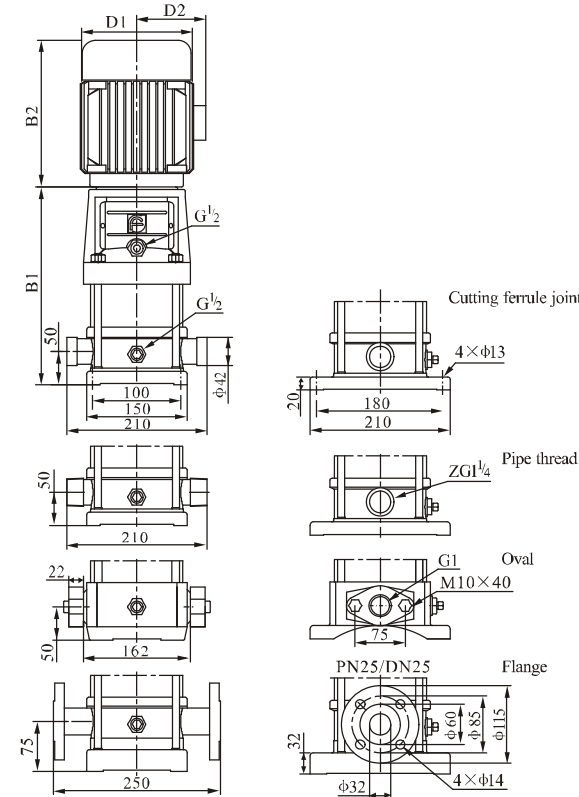

CDL2-18 ~ 2-26 sub-connection of pipeline has no oval flange connection. The overall dimensions of the single-phase motor and explosion-proof motor are a little different. Pls contact us for details.

● Size and weight

Model	Size (mm)					Weight (kg)
	B1	B2	B1+B2	D1	D2	
CDL2-2	258	210	468	148	117	20
CDL2-3	276	210	486	148	117	20
CDL2-4	294	210	504	148	117	20
CDL2-5	312	210	522	148	117	20
CDL2-6	340	245	585	170	142	25
CDL2-7	358	245	603	170	142	25
CDL2-9	394	245	639	170	142	30
CDL2-11	430	245	675	170	142	30
CDL2-13	476	290	766	190	155	35
CDL2-15	512	290	802	190	155	35
CDL2-18	566	290	856	190	155	40
CDL2-22	638	290	928	190	155	45
CDL2-26	720	315	1035	197	165	50

● Performance curve

ISO9906 Annex A 2900rpm

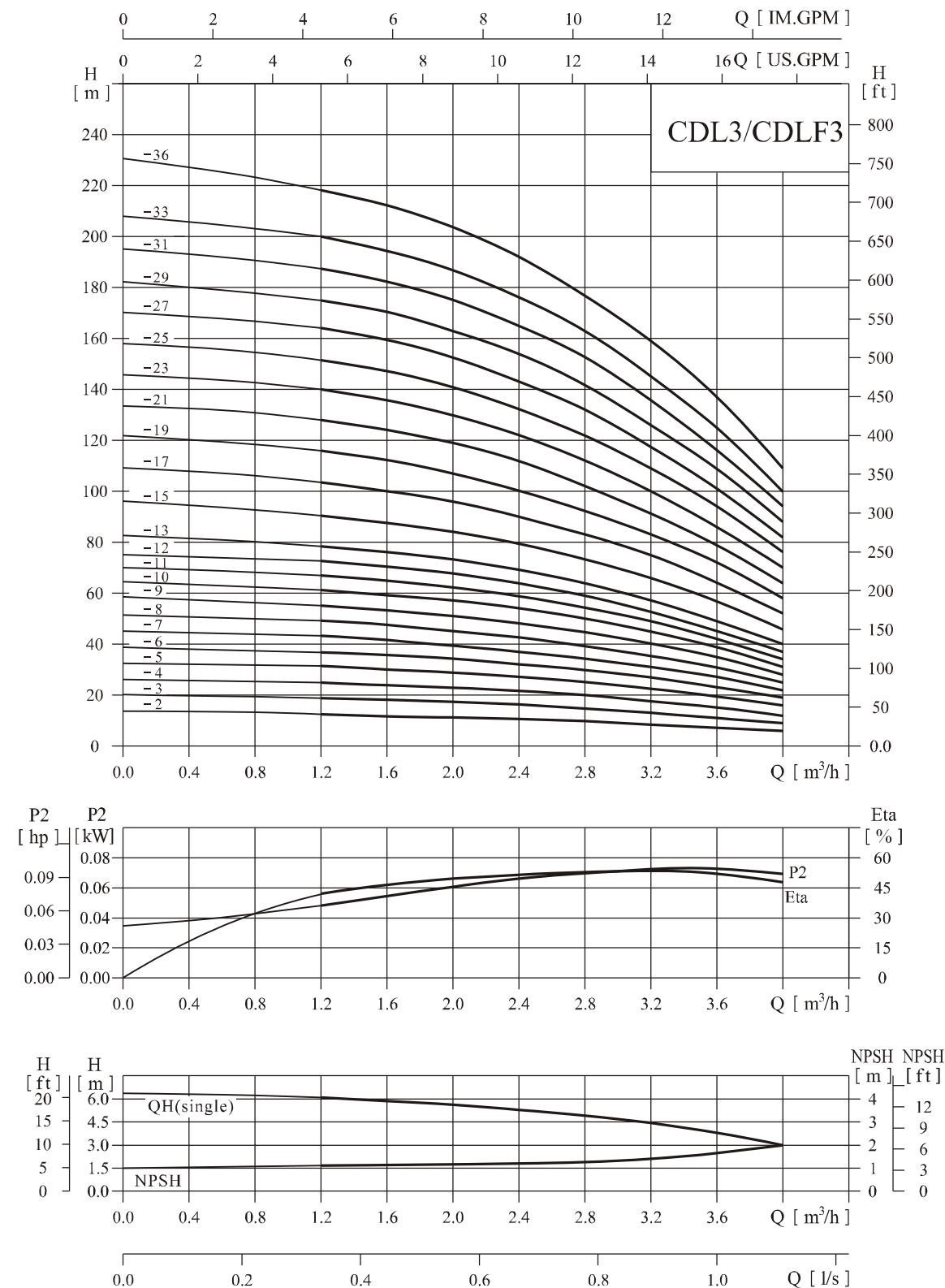

● Performance table

Model	Driving motor		Q (m ³ /h)	1.2	1.6	2.0	2.4	2.8	3.0	3.2	3.6	4.0
	(kW)	(hp)										
CDL3-2	0.37	0.5	12.5	11.5	11	10.5	10	9	8	7	6	6
CDL3-3	0.37	0.5	19	18.5	17.5	16.5	15	14	13	11	9	9
CDL3-4	0.37	0.5	25	24	23	21.5	20	19	18	15	12	12
CDL3-5	0.37	0.5	31	30	29	27	25	23	22	19	16	16
CDL3-6	0.55	0.75	36	35	34	32	30	28	27	23	19	19
CDL3-7	0.55	0.75	43	41	39	37	34	32	31	27	22	22
CDL3-8	0.75	1	49	47	45	43	39	37	35	31	25	25
CDL3-9	0.75	1	55	53	51	48	45	42	40	35	28	28
CDL3-10	0.75	1	61	59	57	54	50	47	45	39	31	31
CDL3-11	1.1	1.5	67	64	61	58	54	51	49	42	34	34
CDL3-12	1.1	1.5	73	70	67	63	58	55	52	45	37	37
CDL3-13	1.1	1.5	78	76	73	69	64	60	57	49	40	40
CDL3-15	1.1	1.5	90	88	84	79	73	69	66	57	46	46
CDL3-17	1.5	2	103	100	96	90	83	79	75	64	52	52
CDL3-19	1.5	2	115	112	107	100	92	88	83	72	58	58
CDL3-21	2.2	3	128	124	119	112	102	98	91	79	64	64
CDL3-23	2.2	3	140	135	130	122	112	107	100	86	70	70
CDL3-25	2.2	3	151	147	141	131	122	116	109	94	76	76
CDL3-27	2.2	3	164	159	152	143	132	124	117	101	82	82
CDL3-29	2.2	3	175	170	163	153	142	133	126	109	88	88
CDL3-31	3.0	4	187	182	175	165	153	142	135	116	94	94
CDL3-33	3.0	4	199	194	187	176	163	151	145	125	100	100
CDL3-36	3.0	4	218	212	204	192	178	168	159	137	109	109

● Installation sketch

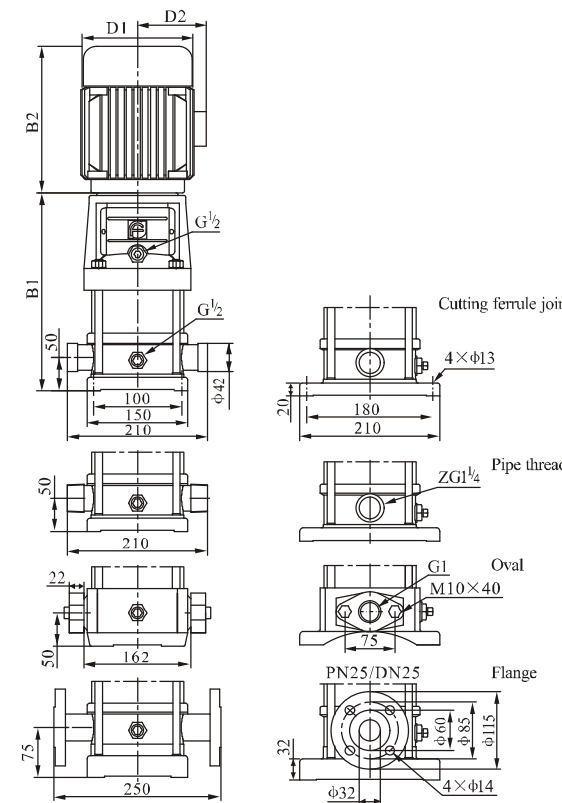

● Size and weight

Model	Size (mm)					Weight (kg)
	B1	B2	B1+B2	D1	D2	
CDL3-2	258	210	468	148	117	20
CDL3-3	276	210	486	148	117	20
CDL3-4	294	210	504	148	117	20
CDL3-5	312	210	522	148	117	20
CDL3-6	330	210	540	148	117	22
CDL3-7	348	210	558	148	117	22
CDL3-8	376	245	621	170	142	22
CDL3-9	394	245	639	170	142	22
CDL3-10	412	245	657	170	142	22
CDL3-11	430	245	675	170	142	25
CDL3-12	448	245	693	170	142	25
CDL3-13	466	245	711	170	142	25
CDL3-15	502	245	747	170	142	25
CDL3-17	548	290	838	190	155	30
CDL3-19	584	290	874	190	155	35
CDL3-21	620	290	910	190	155	35
CDL3-23	656	290	946	190	155	40
CDL3-25	692	290	982	190	155	40
CDL3-27	728	290	1018	190	155	40
CDL3-29	764	290	1054	190	155	40
CDL3-31	810	315	1125	197	165	45
CDL3-33	846	315	1161	197	165	50
CDL3-36	900	315	1215	197	165	50

CDL3-25 ~ 3-36 sub-connection of pipeline has no oval flange connection.
The overall dimensions of the single-phase motor and explosion-proof motor are a little different. Pls contact us for details.

● Performance curve

ISO9906 Annex A 2900rpm

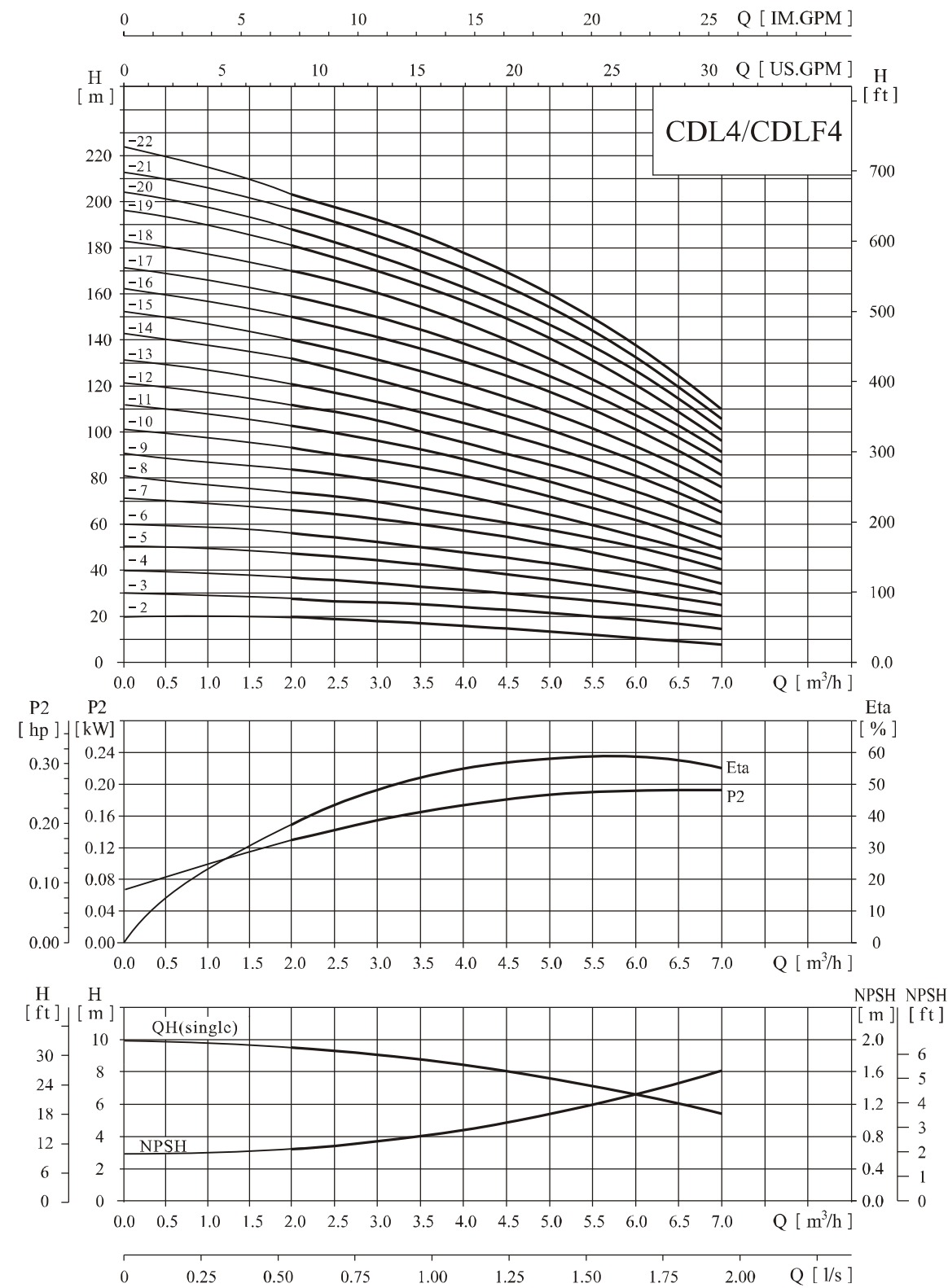

● Performance table

Model	Driving motor		Q (m³/h)	1.5	2.0	3.0	4.0	5.0	6.0	7.0
	(kW)	(hp)								
CDL4-2	0.37	0.5	H (m)	19	18	17	15	13	10	8
CDL4-3	0.55	0.75		28	27	26	24	20	18	13
CDL4-4	0.75	1		38	36	34	32	27	24	19
CDL4-5	1.1	1.5		47	45	43	40	34	31	23
CDL4-6	1.1	1.5		56	54	52	48	41	37	28
CDL4-7	1.5	2		66	63	61	56	48	43	33
CDL4-8	1.5	2		74	72	70	64	55	50	38
CDL4-10	2.2	3		96	90	87	81	71	62	48
CDL4-12	2.2	3		114	108	104	95	85	75	58
CDL4-14	3.0	4		136	126	122	112	101	89	68
CDL4-16	3.0	4		152	144	140	129	115	101	78
CDL4-19	4.0	5.5		183	171	168	153	137	122	93
CDL4-22	4.0	5.5		211	200	192	178	160	138	108

● Installation sketch

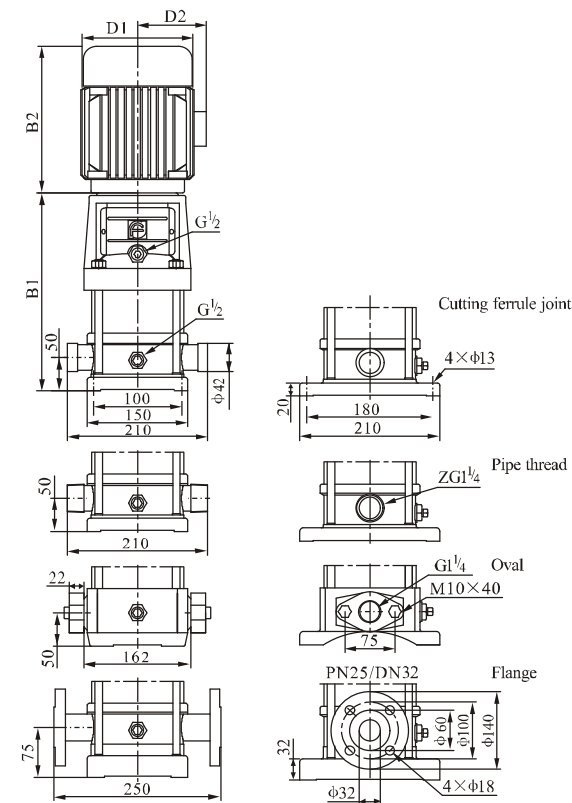

● Size and weight

Model	Size (mm)					Weight (kg)
	B1	B2	B1+B2	D1	D2	
CDL4-2	276	210	486	148	117	20
CDL4-3	303	210	513	148	117	20
CDL4-4	340	245	585	170	142	20
CDL4-5	367	245	612	170	142	25
CDL4-6	394	245	639	170	142	25
CDL4-7	431	290	721	190	155	30
CDL4-8	458	290	748	190	155	30
CDL4-10	512	290	802	190	155	30
CDL4-12	566	290	856	190	155	35
CDL4-14	630	315	945	197	165	35
CDL4-16	684	315	999	197	165	40
CDL4-19	765	335	1100	230	188	45
CDL4-22	846	335	1181	230	188	50

CDL4-19 ~ 4-22 sub-connection of pipeline has no oval flange connection. The overall dimensions of the single-phase motor and explosion-proof motor are a little different. Pls contact us for details.

● Performance curve

ISO9906 Annex A 2900rpm

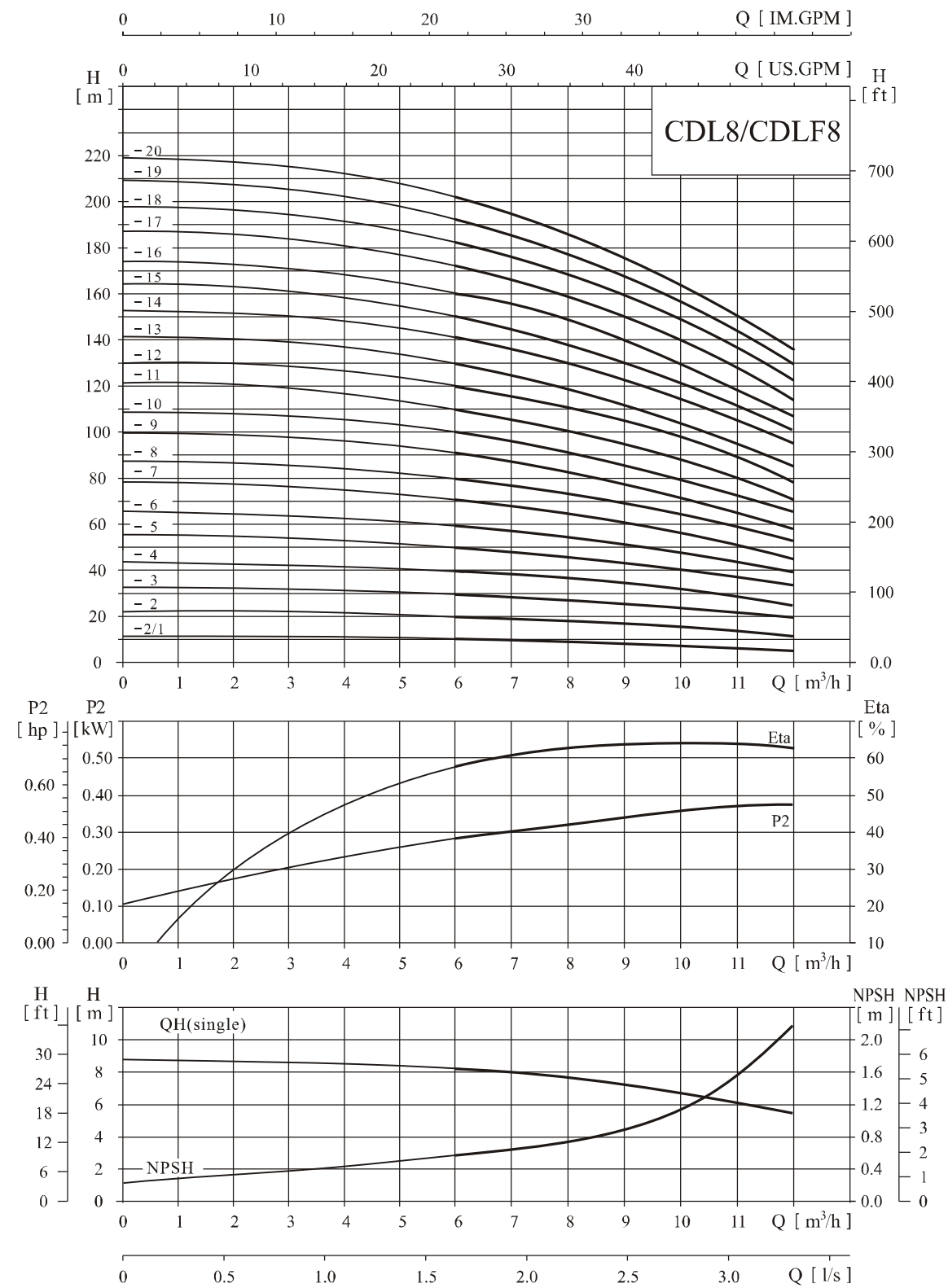

● Performance table

Model	Driving motor		Q (m³/h)	5	6	7	8	9	10	11	12
	(kW)	(hp)									
CDL8-2/1	0.75	1		10	9.5	9.3	9	8.5	8	7	6
CDL8-2	0.75	1		20	19.5	19	18	17	16	14	13
CDL8-3	1.1	1.5		30	29.5	28.5	27	25	24	21	19
CDL8-4	1.5	2		41	39.5	38	36	34	32	28	26
CDL8-5	2.2	3		52	50	48	45	42	40	36	32
CDL8-6	2.2	3		62	60	57	54	51	48	43	39
CDL8-8	3.0	4		83	80	77	73	69	65	58	52
CDL8-10	4.0	5.5		104	100	97	92	87	81	73	65
CDL8-12	4.0	5.5		124	120	116	111	104	92	87	78
CDL8-14	5.5	7.5		145	141	136	130	122	113	102	92
CDL8-16	5.5	7.5		166	161	156	148	139	130	118	106
CDL8-18	7.5	10		187	182	175	167	157	146	134	120
CDL8-20	7.5	10		208	202	195	186	175	163	150	135

● Installation sketch

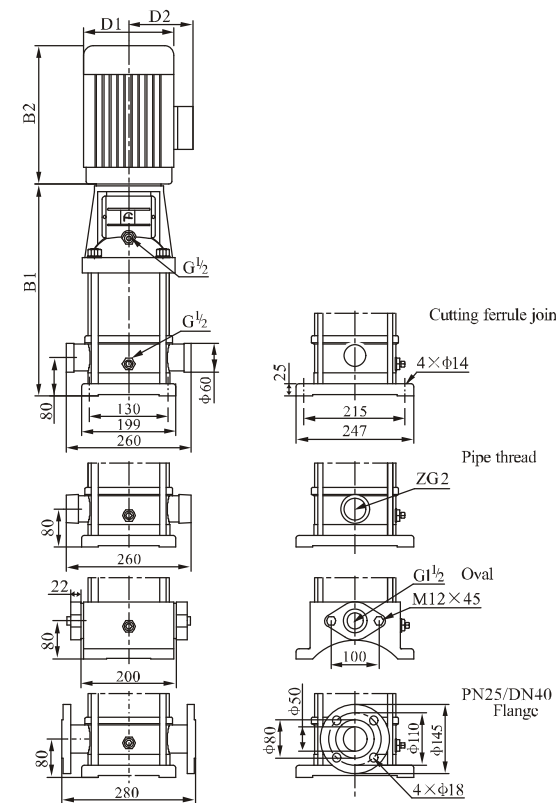

● Size and weight

Model	Size (mm)					Weight (kg)
	B1	B2	B1+B2	D1	D2	
CDL8-2/1	347	245	592	170	142	22
CDL8-2	347	245	592	170	142	22
CDL8-3	377	245	622	170	142	32
CDL8-4	417	290	707	190	155	32
CDL8-5	447	290	737	190	155	42
CDL8-6	477	290	767	190	155	42
CDL8-8	547	315	862	197	165	47
CDL8-10	607	335	942	230	188	57
CDL8-12	667	335	1002	230	188	57
CDL8-14	747	430	1177	260	208	82
CDL8-16	807	430	1237	260	208	82
CDL8-18	867	430	1297	260	208	92
CDL8-20	927	430	1357	260	208	92

CDL8-14 ~ 8-20 sub-connection of pipeline has no oval flange connection. The overall dimensions of the single-phase motor and explosion-proof motor are a little different. Pls contact us for details.

● Performance curve

ISO9906 Annex A 2900rpm

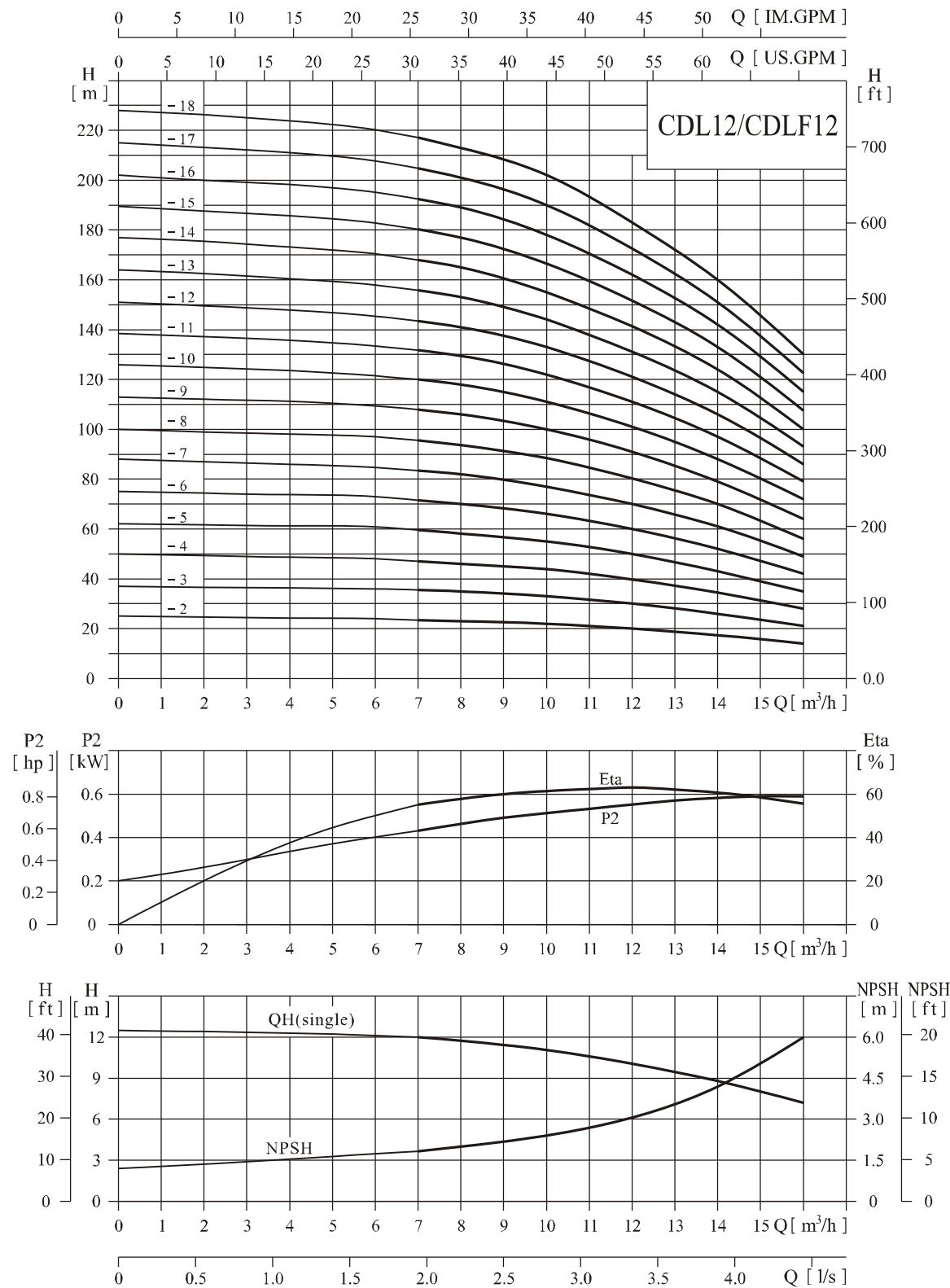

● Performance table

Model	Driving motor		Q (m³/h)	H (m)										
	(kW)	(hp)		7	8	9	10	11	12	13	14	15	16	
CDL12-2	1.5	2	7	23.5	23	22.5	22	21	20	18.5	17	15.5	14	
CDL12-3	2.2	3	8	35.5	35	34	33	31.5	30	28	26	23.5	21	
CDL12-4	3	4	9	47	46	45	44	42	40	37	34	31	28	
CDL12-5	3	4	10	59.5	58	56.5	55	52.5	50	46.5	43	39	35	
CDL12-6	4	5.5	11	71.5	70	68	66	63	60	56	52	47	42	
CDL12-7	5.5	7.5	12	83.5	82	79.5	77	73.5	70	65.5	61	55	49	
CDL12-8	5.5	7.5	13	95.5	94	91	88	84	80	75	70	63	56	
CDL12-9	5.5	7.5	14	108	106	103	100	95.5	91	85	79	71.5	64	
CDL12-10	7.5	10	15	120	118	114.5	111	106	101	94.5	88	80	72	
CDL12-12	7.5	10	16	143.5	141	137	133	127	121	113.5	106	96	86	
CDL12-14	11	15	17	168	165	160	155	148	141	132.5	124	112	100	
CDL12-16	11	15	18	192.5	189	183.5	178	170	162	152	142	128.5	115	
CDL12-18	11	15	19	217	213	207.5	202	192.5	183	171.5	160	145	130	

● Installation sketch

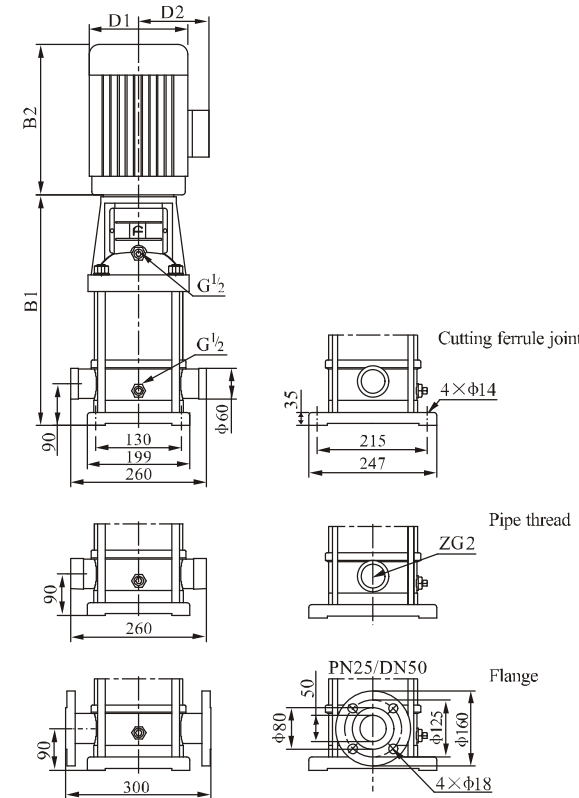

● Size and weight

Model	Size (mm)					Weight (kg)
	B1	B2	B1+B2	D1	D2	
CDL12-2	367	290	657	190	155	36
CDL12-3	397	290	687	190	155	39
CDL12-4	437	315	752	197	165	46
CDL12-5	467	315	782	197	165	47
CDL12-6	497	335	832	230	188	57
CDL12-7	547	430	977	260	208	75
CDL12-8	577	430	1007	260	208	75
CDL12-9	607	430	1037	260	208	77
CDL12-10	637	430	1067	260	208	77
CDL12-12	697	430	1127	260	208	79
CDL12-14	845	490	1335	330	255	150
CDL12-16	905	490	1395	330	255	150
CDL12-18	965	490	1455	330	255	152

The overall dimensions of the single-phase motor and explosion-proof motor are a little different. Pls contact us for details.

● Performance curve

ISO9906 Annex A 2900rpm

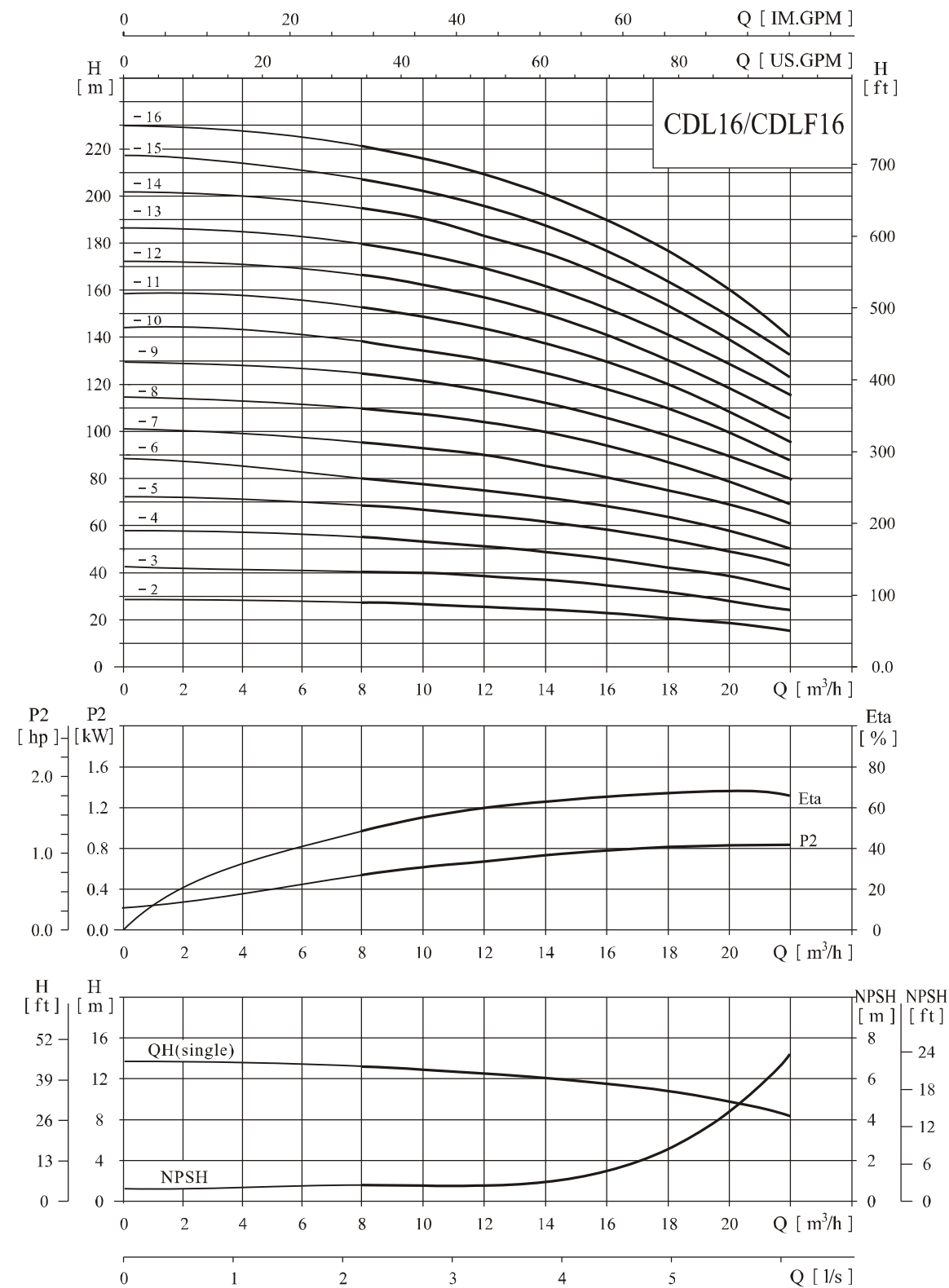

● Performance table

Model	Driving motor		Q (m³/h)	8	10	12	14	16	18	20	22
	(kW)	(hp)									
CDL16-2	2.2	3	H (m)	27	26	25	24	22	21	19	16
CDL16-3	3.0	4		41	40	38	37	34	32	29	25
CDL16-4	4.0	5.5		54	53	52	49	46	43	38	34
CDL16-5	5.5	7.5		68	67	65	62	58	54	48	43
CDL16-6	5.5	7.5		82	80	78	74	70	64	58	52
CDL16-7	7.5	10		96	95	91	87	82	76	68	61
CDL16-8	7.5	10		110	108	104	99	94	86	77	70
CDL16-10	11	15		138	136	131	125	118	109	97	87
CDL16-12	11	15		166	162	157	150	141	130	116	105
CDL16-14	15	20		194	190	184	175	166	152	136	122
CDL16-16	15	20		222	217	210	200	189	174	156	140

● Installation sketch

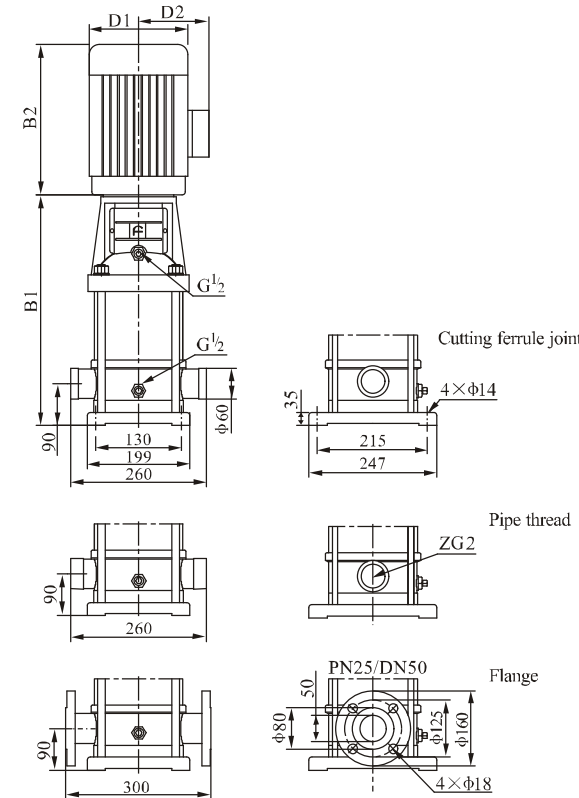

● Size and weight

Model	Size (mm)					Weight (kg)
	B1	B2	B1+B2	D1	D2	
CDL16-2	397	290	687	190	155	42
CDL16-3	452	315	767	197	165	52
CDL16-4	497	335	832	230	188	57
CDL16-5	562	430	992	260	208	72
CDL16-6	607	430	1037	260	208	77
CDL16-7	652	430	1082	260	208	82
CDL16-8	697	430	1127	260	208	82
CDL16-10	875	490	1365	330	255	142
CDL16-12	965	490	1455	330	255	147
CDL16-14	1055	490	1545	330	255	162
CDL16-16	1145	490	1635	330	255	167

The overall dimensions of the single-phase motor and explosion-proof motor are a little different. Pls contact us for details.

● Performance curve

ISO9906 Annex A 2900rpm

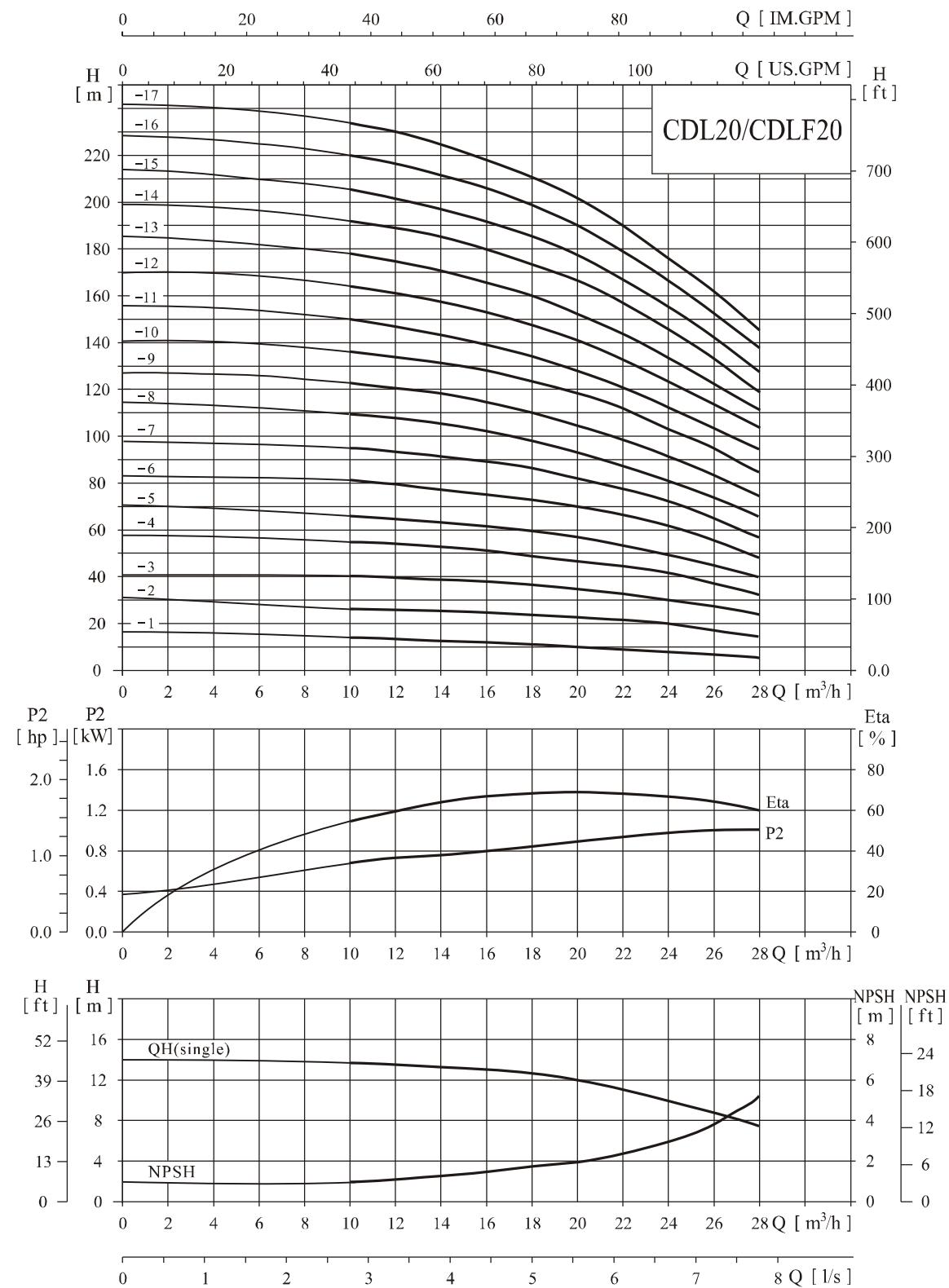

● Performance table

Model	Driving motor		Q (m³/h)	10	12	14	16	18	20	22	24	26	28
	(kW)	(hp)											
CDL20-1	1.1	1.5		13.5	13	12.5	12	11	10	9	8	7	6
CDL20-2	2.2	3		27	26.5	26	25	24	23	22	20	18	15
CDL20-3	4.0	5.5		40	39.5	39	38	37	35	33	30	27	24
CDL20-4	5.5	7.5		54	53	52	51	49	47	44	41	37	33
CDL20-5	5.5	7.5		67	66	64	62	60	58	55	50	45	40
CDL20-6	7.5	10		81	79	77	75	73	70	66	61	55	49
CDL20-7	7.5	10		95	93	91	89	86	82	77	71	65	58
CDL20-8	11	15		109	107	105	102	99	94	89	82	75	67
CDL20-10	11	15		136	134	131	128	124	118	111	103	95	85
CDL20-12	15	20		164	162	158	154	149	142	133	124	114	102
CDL20-14	15	20		192	189	185	180	174	166	156	145	133	119
CDL20-17	18.5	25		234	230	225	219	212	202	190	177	162	145

● Installation sketch

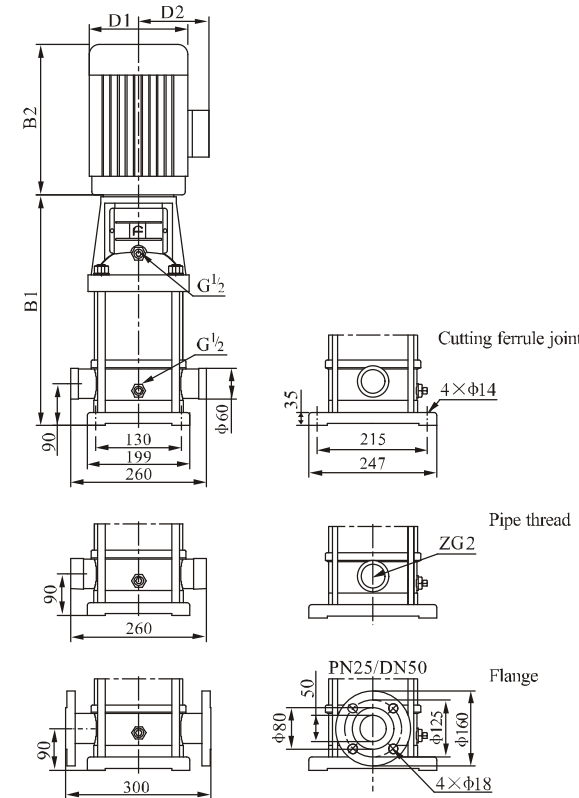

● Size and weight

Model	Size (mm)					Weight (kg)
	B1	B2	B1+B2	D1	D2	
CDL20-1	387	245	632	170	142	32
CDL20-2	397	290	687	190	155	43
CDL20-3	452	335	787	230	188	57
CDL20-4	517	430	947	260	208	72
CDL20-5	562	430	992	260	208	74
CDL20-6	607	430	1037	260	208	82
CDL20-7	652	430	1082	260	208	84
CDL20-8	785	490	1275	330	255	140
CDL20-10	875	490	1365	330	255	145
CDL20-12	965	490	1455	330	255	160
CDL20-14	1055	490	1545	330	255	165
CDL20-17	1190	550	1740	330	255	190

The overall dimensions of the single-phase motor and explosion-proof motor are a little different. Pls contact us for details.

● Performance curve

ISO9906 Annex A 2900rpm

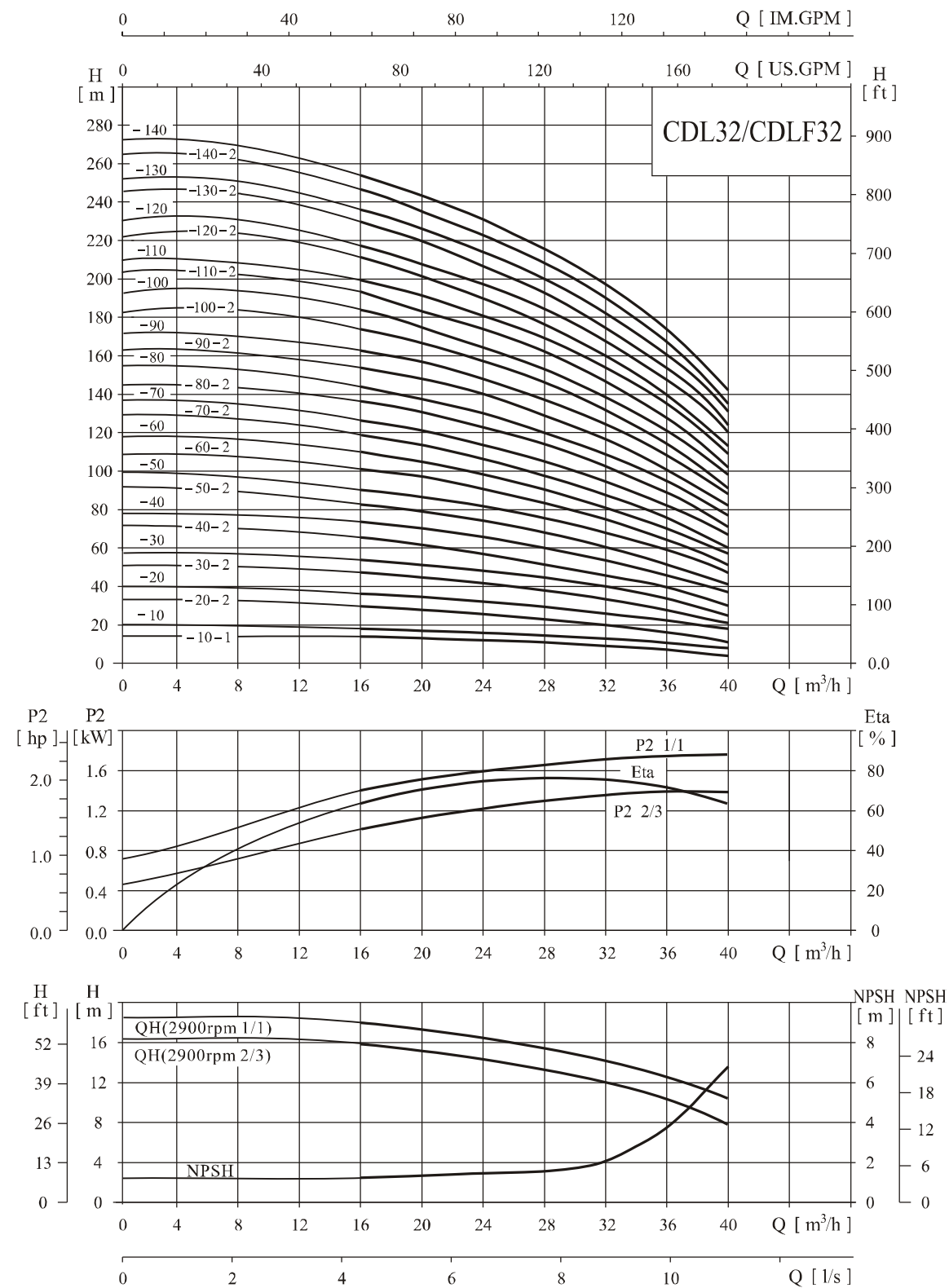

● Performance table

Model	Driving motor		Q (m³/h)	16	20	24	28	32	36	40	Model	Driving motor		Q (m³/h)	16	20	24	28	32	36	40
	(kW)	(hp)										(kW)	(hp)								
CDL32-10-1	1.5	2	H (m)	14	13	12	11	9	7	4	CDL32-80-2	15	20	H (m)	136	131	123	114	102	90	71
CDL32-10	2.2	3		18	17	15	14	13	11	8	CDL32-80	15	20		144	138	130	120	109	97	77
CDL32-20-2	3.0	4		29	28	26	23	20	16	11	CDL32-90-2	18.5	25		154	148	140	129	117	102	82
CDL32-20	4.0	5.5		36	34	32	29	27	23	18	CDL32-90	18.5	25		162	156	147	136	124	109	88
CDL32-30-2	5.5	7.5		47	44	41	38	33	28	21	CDL32-100-2	18.5	25		175	166	157	146	131	115	91
CDL32-30	5.5	7.5		54	51	48	44	40	35	27	CDL32-100	18.5	25		182	173	164	152	138	122	98
CDL32-40-2	7.5	10		65	62	58	53	46	40	30	CDL32-110-2	22	30		193	184	173	164	146	128	102
CDL32-40	7.5	10		72	69	65	59	53	47	37	CDL32-110	22	30		200	191	180	168	153	135	109
CDL32-50-2	11	15		83	79	74	68	60	52	41	CDL32-120-2	22	30		211	201	189	178	160	140	113
CDL32-50	11	15		90	86	81	74	67	59	47	CDL32-120	22	30		218	208	196	184	167	147	120
CDL32-60-2	11	15		101	97	90	83	74	65	51	CDL32-130-2	30	40		230	218	206	193	174	153	124
CDL32-60	11	15		108	104	97	90	81	72	57	CDL32-130	30	40		237	225	213	200	181	160	131
CDL32-70-2	15	20		119	114	107	98	88	78	60	CDL32-140-2	30	40		247	235	222	210	189	165	135
CDL32-70	15	20		126	121	113	105	95	85	67	CDL32-140	30	40		255	242	229	216	196	172	142

● Installation sketch

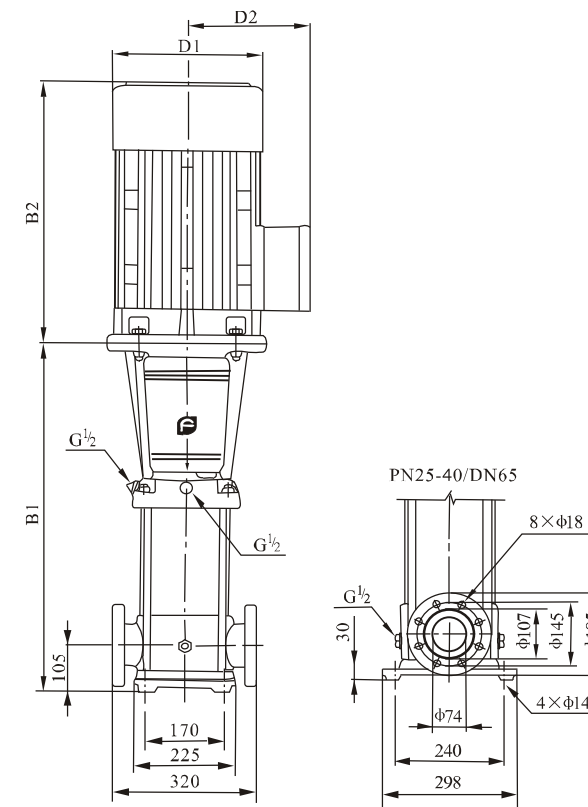

● Size and weight

Model	Size (mm)					Weight (kg)
	B1	B2	B1+B2	D1	D2	
CDL32-10-1/CDL32-10	505	290	795	190	155	68/71
CDL32-20-2/CDL32-20	575	315/335	890/910	197/230	165/180	78/84
CDL32-30-2/CDL32-30	645	430	1075	260	208	93
CDL32-40-2/CDL32-40	715	430	1145	260	208	102
CDL32-50-2/CDL32-50	890	490	1380	330	255	172
CDL32-60-2/CDL32-60	960	490	1450	330	255	176
CDL32-70-2/CDL32-70	1030	490	1520	330	255	188
CDL32-80-2/CDL32-80	1100	490	1590	330	255	192
CDL32-90-2/CDL32-90	1170	550	1720	330	255	218
CDL32-100-2/CDL32-100	1240	550	1790	330	255	222
CDL32-110-2/CDL32-110	1310	590	1900	360	285	259
CDL32-120-2/CDL32-120	1380	590	1970	360	285	263
CDL32-130-2/CDL32-130	1450	660	2110	400	310	327
CDL32-140-2/CDL32-140	1520	660	2180	400	310	331

The overall dimensions of the single-phase motor and explosion-proof motor are a little different. Pls contact us for details.

● Performance curve

ISO9906 Annex A 2900rpm

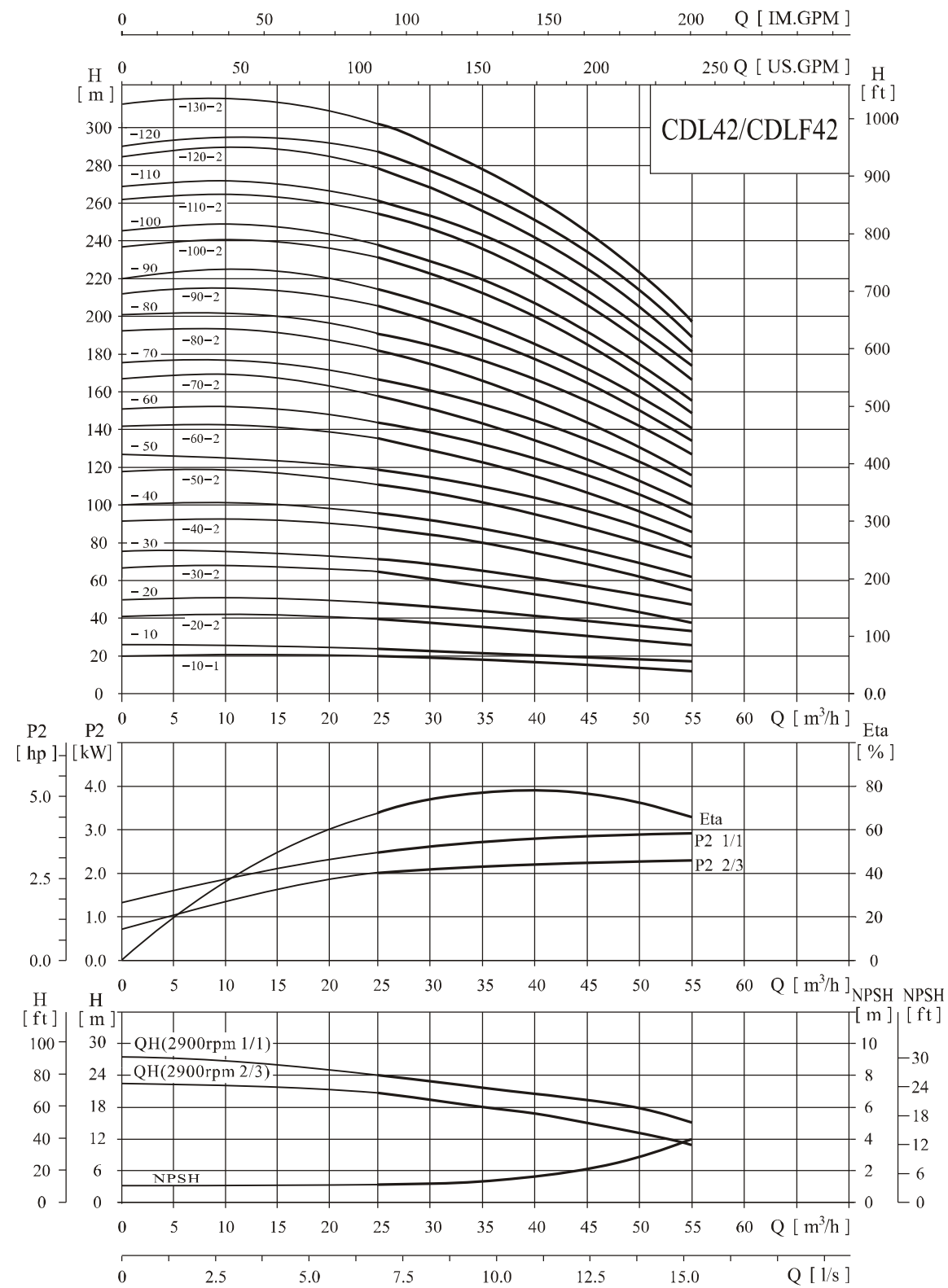

● Performance table

Model	Driving motor		Q (m³/h)	25	30	35	40	42	45	50	55
	(kW)	(hp)									
CDL42-10-1	3.0	4	20	19	18	17	16	15	13	11	
CDL42-10	4.0	5.5	24	23	22	21	20	19	18	16	
CDL42-20-2	5.5	7.5	40	38	36	33	32	30	27	23	
CDL42-20	7.5	10	48	46	44	42	41	39	35	31	
CDL42-30-2	11	15	63	61	58	54	52	50	44	38	
CDL42-30	11	15	71	69	66	63	61	58	53	47	
CDL42-40-2	15	20	87	84	80	75	73	69	62	54	
CDL42-40	15	20	95	92	88	84	81	78	71	62	
CDL42-50-2	18.5	25	111	107	102	96	93	88	80	69	
CDL42-50	18.5	25	119	115	110	105	101	97	88	78	
CDL42-60-2	22	30	135	130	124	117	113	108	97	85	
CDL42-60	22	30	143	138	132	125	122	116	106	93	
CDL42-70-2	30	40	158	152	146	138	134	127	115	100	
CDL42-70	30	40	166	161	154	146	142	135	124	109	
CDL42-80-2	30	40	182	175	168	159	154	146	133	116	
CDL42-80	30	40	190	184	176	167	162	154	141	124	
CDL42-90-2	30	40	205	198	190	180	174	166	150	132	
CDL42-90	37	50	214	207	198	188	183	174	159	140	
CDL42-100-2	37	50	230	221	212	200	194	185	168	147	
CDL42-100	37	50	238	230	220	209	203	193	177	155	
CDL42-110-2	45	60	255	246	236	223	217	206	188	165	
CDL42-110	45	60	263	255	244	232	225	214	196	173	
CDL42-120-2	45	60	280	270	259	245	238	226	206	181	
CDL42-120	45	60	289	280	268	255	247	236	216	190	
CDL42-130-2	45	60	305	294	282	267	259	247	225	198	

● Installation sketch

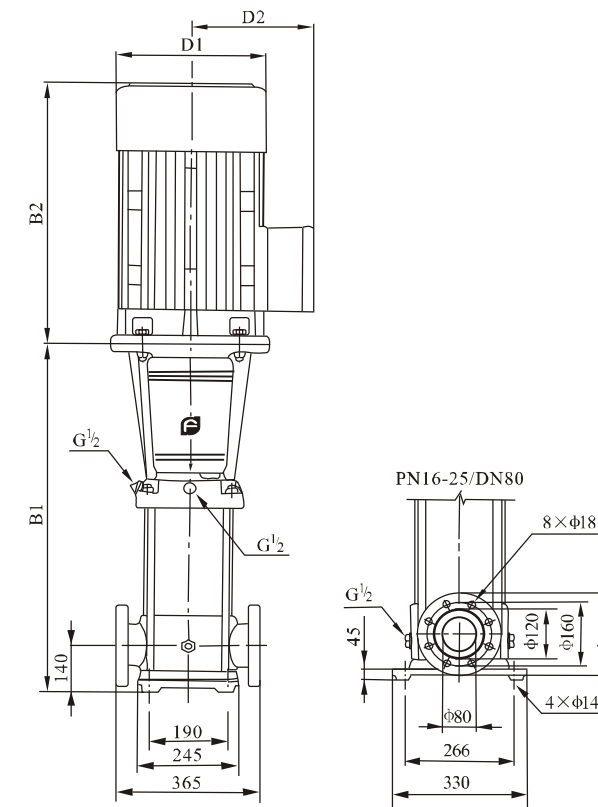

● Size and weight

Model	Size (mm)					Weight (kg)
	B1	B2	B1+B2	D1	D2	
CDL42-10-1	561	315/335	876/896	197/230	165/188	86/92
CDL42-10	641	430	1071	260	208	102/107
CDL42-20-2	826	490	1316	330	255	175
CDL42-20	906	490	1396	330	255	187
CDL42-30-2	986	550	1536	330	255	208
CDL42-30	1066	590	1656	360	285	251
CDL42-40-2	1146	660	1806	400	310	315
CDL42-40	1226	660	1886	400	310	319
CDL42-50-2	1306	660	1966	400	310	323/343
CDL42-50	1386	660	2046	400	310	347
CDL42-60-2	1466	700	2166	450	345	413
CDL42-60	1546	700	2246	450	345	417
CDL42-70-2	1626	700	2326	450	345	421

The overall dimensions of the single-phase motor and explosion-proof motor are a little different. Pls contact us for details.

● Performance curve

ISO9906 Annex A 2900rpm

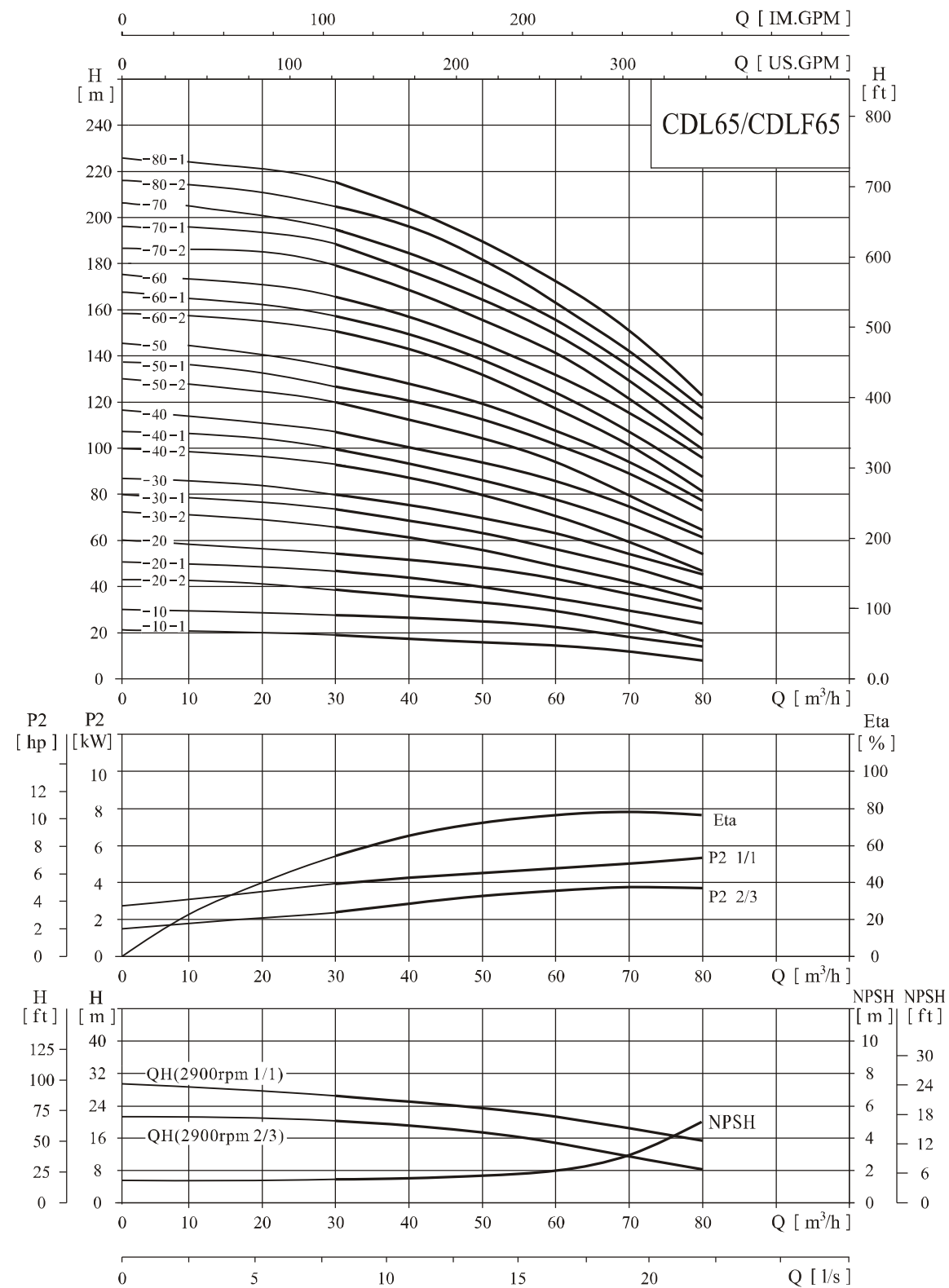

● Performance table

Model	Driving motor		Q (m³/h)	30	40	50	60	65	70	80
	(kW)	(hp)								
CDL65-10-1	4.0	5.5	19	18	16	14	13	11	8	
CDL65-10	5.5	7.5	27	25	23	21	20	18	15	
CDL65-20-2	7.5	10	39	36	33	29	26	23	17	
CDL65-20-1	11	15	46	44	40	36	33	30	24	
CDL65-20	11	15	53	51	47	43	40	37	30	
CDL65-30-2	15	20	66	62	56	50	46	41	32	
CDL65-30-1	15	20	73	69	63	57	53	48	39	
CDL65-30	18.5	25	80	76	70	64	60	55	46	
CDL65-40-2	18.5	25	92	87	80	71	66	60	47	
CDL65-40-1	22	30	100	94	87	78	73	67	54	
CDL65-40	22	30	107	101	94	85	80	74	61	
CDL65-50-2	30	40	121	114	105	95	88	80	64	
CDL65-50-1	30	40	128	121	112	102	95	87	71	
CDL65-50	30	40	136	129	119	109	102	94	78	
CDL65-60-2	30	40	150	142	131	118	110	101	81	
CDL65-60-1	37	50	157	149	138	125	117	108	88	
CDL65-60	37	50	164	156	145	132	124	115	95	
CDL65-70-2	37	50	179	169	156	141	132	121	99	
CDL65-70-1	37	50	186	176	163	148	139	128	106	
CDL65-70	45	60	193	183	170	155	146	135	112	
CDL65-80-2	45	60	207	196	182	164	154	142	116	
CDL65-80-1	45	60	215	203	189	171	161	149	123	

● Installation sketch

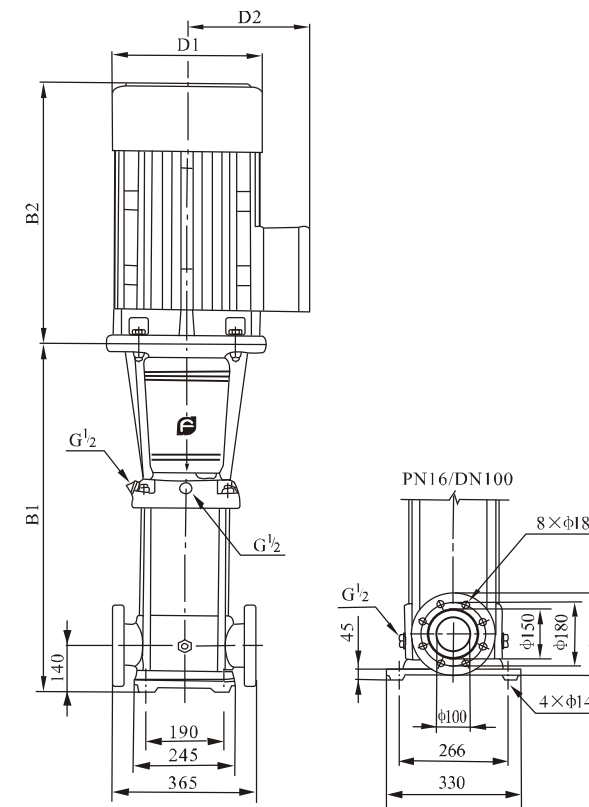

● Size and weight

Model	Size (mm)					Weight (kg)
	B1	B2	B1+B2	D1	D2	
CDL65-10-1	561	335	896	230	188	105
CDL65-10	561	430	991	260	208	110
CDL65-20-2	644	430	1074	260	208	120
CDL65-20-1	754	490	1244	330	255	155
CDL65-20	754	490	1244	330	255	155
CDL65-30-2	836	490	1326	330	255	195
CDL65-30-1	836	490	1326	330	255	195
CDL65-30	836	550	1386	330	255	205
CDL65-40-2	919	550	1469	330	255	208
CDL65-40-1	919	590	1509	360	285	260
CDL65-40	919	590	1509	360	285	260
CDL65-50-2	1001	660	1661	400	310	345
CDL65-50-1	1001	660	1661	400	310	345
CDL65-50	1001	660	1661	400	310	345
CDL65-60-2	1084	660	1744	400	310	350
CDL65-60-1	1084	660	1744	400	310	370
CDL65-60	1084	660	1744	400	310	370
CDL65-70-2	1166	660	1826	400	310	375
CDL65-70-1	1166	660	1826	400	310	375
CDL65-70	1166	700	1866	460	340	435
CDL65-80-2	1248	700	1948	460	340	440
CDL65-80-1	1248	700	1948	460	340	440

The overall dimensions of the single-phase motor and explosion-proof motor are a little different. Pls contact us for details.

● Performance curve

ISO9906 Annex A 2900rpm

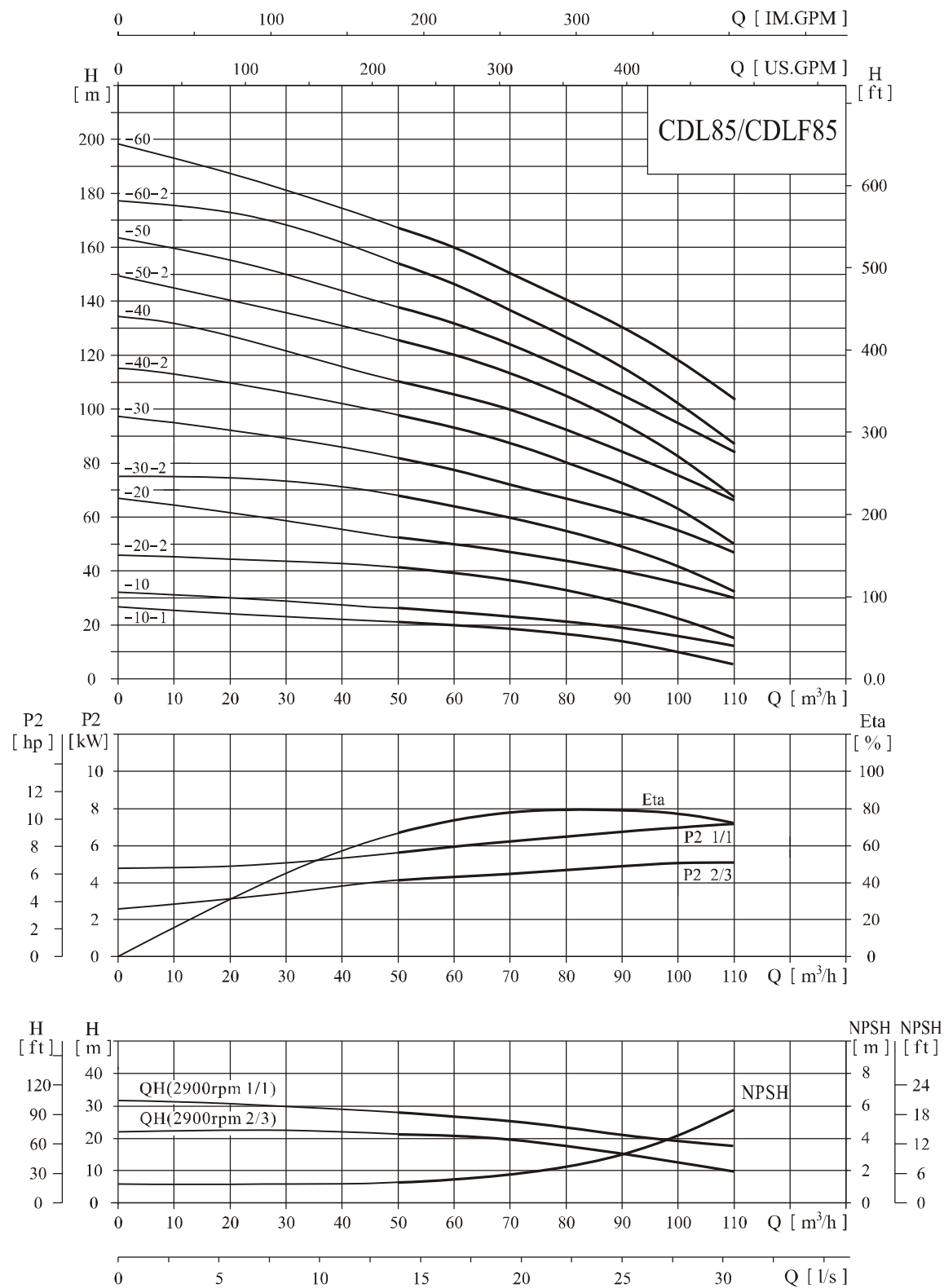

● Performance table

Model	Driving motor		Q (m³/h)	50	60	70	80	85	90	100	110
	(kW)	(hp)									
CDL85-10-1	5.5	7.5	H (m)	22	19	17	16	14	13	10	6
CDL85-10	7.5	10		25	24	22	21	20	19	16	12
CDL85-20-2	11	15		41	39	36	32	30	28	22	15
CDL85-20	15	20		53	50	47	44	41	40	36	30
CDL85-30-2	18.5	25		68	65	60	55	52	49	41	32
CDL85-30	22	30		81	77	72	67	64	62	55	48
CDL85-40-2	30	40		98	93	87	80	75	72	62	50
CDL85-40	30	40		110	105	100	92	86	84	76	66
CDL85-50-2	37	50		126	120	113	104	98	93	81	68
CDL85-50	37	50		139	131	124	115	110	106	94	83
CDL85-60-2	45	60		155	148	139	129	122	117	102	86
CDL85-60	45	60		168	160	150	141	134	130	117	103

● Installation sketch

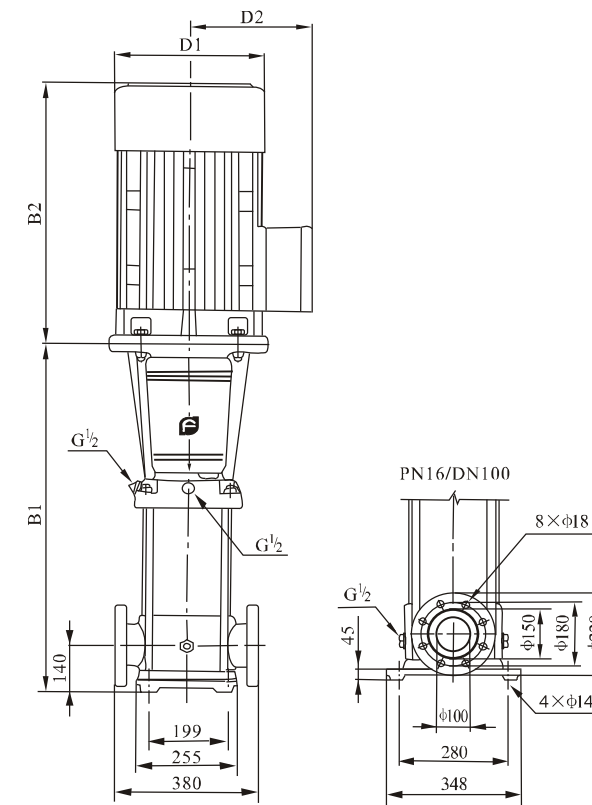

● Size and weight

Model	Size (mm)					Weight (kg)
	B1	B2	B1+B2	D1	D2	
CDL85-10-1	571	430	1001	260	208	120
CDL85-10	571	430	1001	260	208	122
CDL85-20-2	773	490	1263	330	255	165
CDL85-20	773	490	1263	330	255	198
CDL85-30-2	865	550	1415	330	255	212
CDL85-30	865	590	1455	360	285	265
CDL85-40-2	957	660	1617	400	310	348
CDL85-40	957	660	1617	400	310	348
CDL85-50-2	1049	660	1709	400	310	375
CDL85-50	1049	660	1709	400	310	375
CDL85-60-2	1141	700	1841	460	340	438
CDL85-60	1141	700	1841	460	340	438

The overall dimensions of the single-phase motor and explosion-proof motor are a little different. Pls contact us for details.

● Performance curve

ISO9906 Annex A 2950rpm

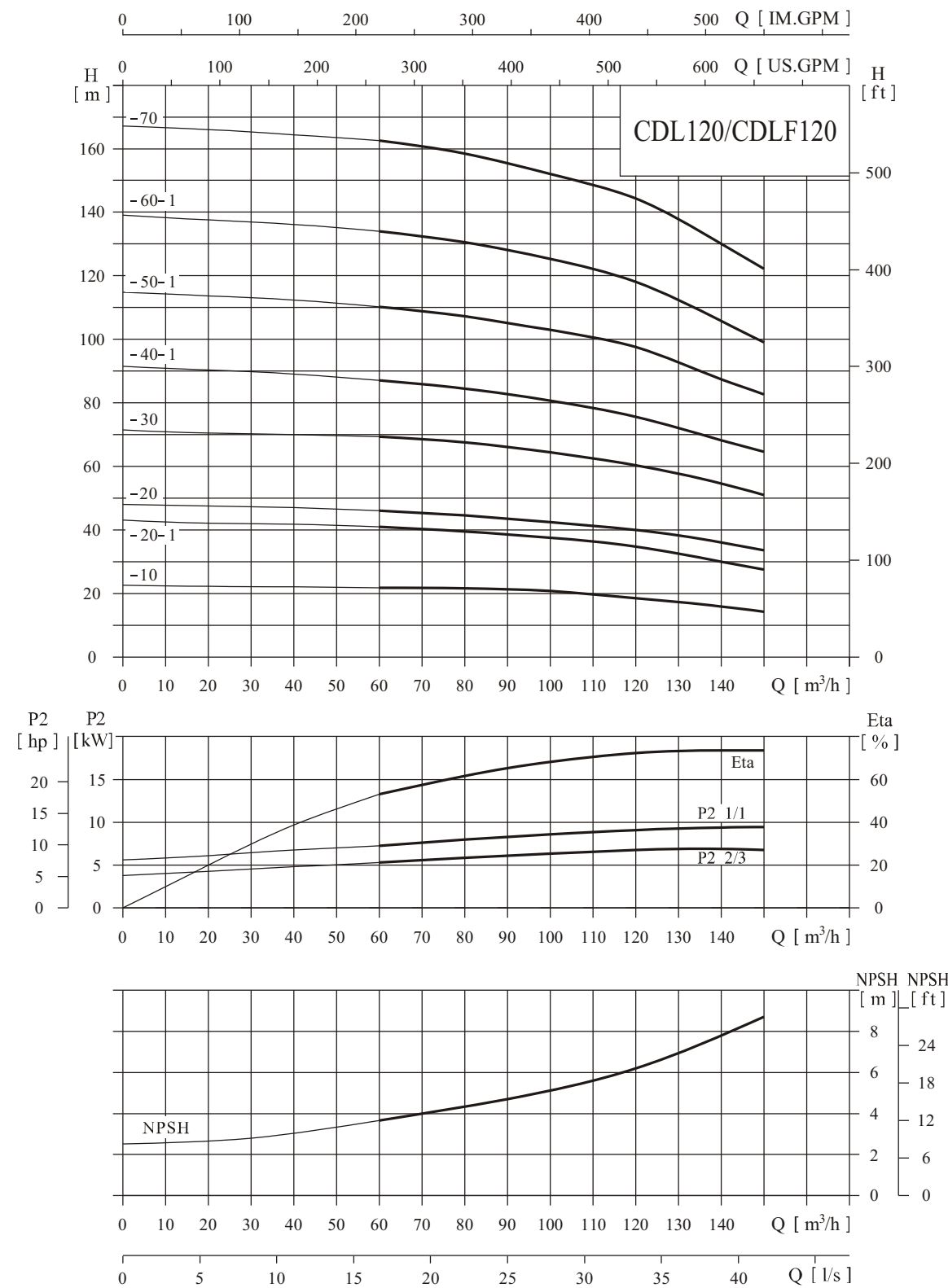

● Performance table

Model	Driving motor		Q (m³/h)	H (m)										
	(kW)	(hp)		60	70	80	90	100	110	120	130	140	150	
CDL120-10	11	15		22	21.8	21.6	21	20.5	19.5	18.5	17	16	15	
CDL120-20-1	18.5	25		41	40	39.5	38.5	37	36.5	34.5	32.5	30	27.5	
CDL120-20	22	30		46	45	44.5	43.5	42.4	41	40	38	36	33.5	
CDL120-30	30	40		69.5	68.5	67.5	66	64.4	62.5	61	57.5	54.5	51	
CDL120-40-1	37	50		87	86	84.5	82	80	78	76	72	68	64.5	
CDL120-50-1	45	60		110.5	109	107.5	105	102	100	97	92	86.5	83	
CDL120-60-1	55	75		134	132	130.5	127	124	121	118	111	105	100	
CDL120-70	75	100		162.5	160.5	158.5	155	151	148	145	137	129	123	

● Installation sketch

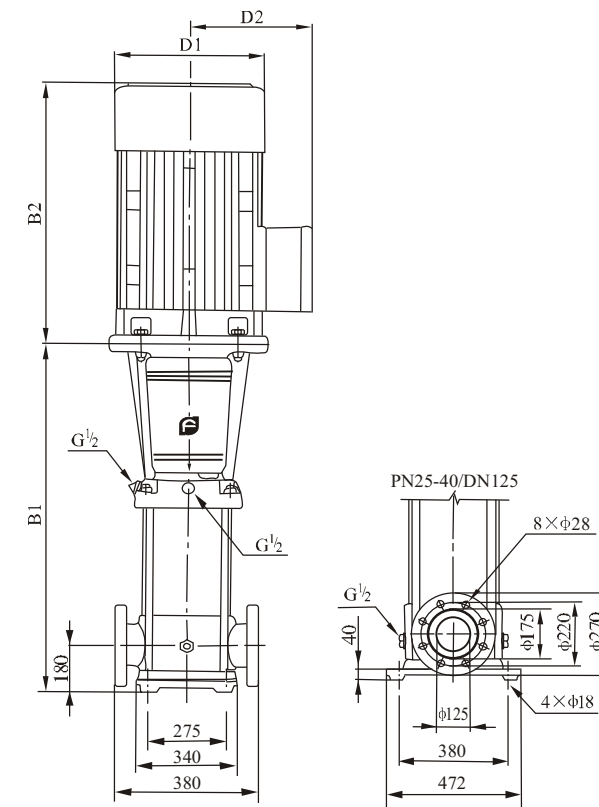

● Size and weight

Model	Size (mm)					Weight (kg)
	B1	B2	B1+B2	D1	D2	
CDL120-10	840	490	1330	330	255	230
CDL120-20-1	1000	550	1550	330	255	250
CDL120-20	1000	590	1590	360	285	285
CDL120-30	1160	660	1820	400	310	360
CDL120-40-1	1320	660	1980	400	310	400
CDL120-50-1	1480	700	2180	460	340	470
CDL120-60-1	1670	770	2440	540	370	585
CDL120-70	1830	845	2675	580	410	715

The overall dimensions of the single-phase motor and explosion-proof motor are a little different. Pls contact us for details.

● Performance curve

ISO9906 Annex A 2950rpm

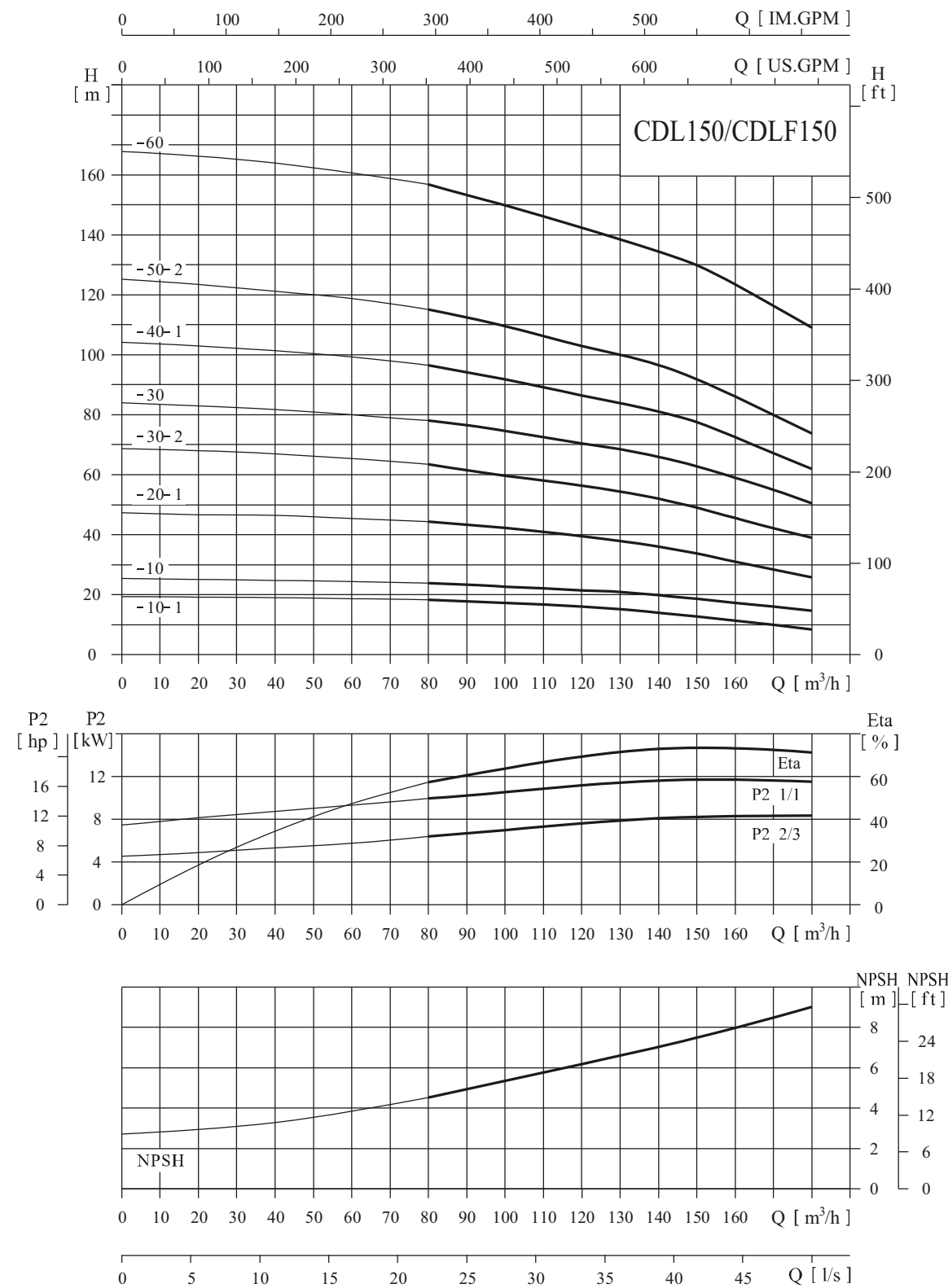

● Performance table

Model	Driving motor		Q (m³/h)	80	90	100	110	120	130	140	150	160	170	180
	(kW)	(hp)												
CDL150-10-1	11	15	H (m)	18.3	17.8	17.3	17	16	15	14	12.5	11	10	8.5
CDL150-10	15	20		24	23	22.5	22	21.5	20.5	20	18.5	17	16	15
CDL150-20-1	22	30		44.3	43	42	40	39	38.5	37.5	35	33	30	27
CDL150-30-2	30	40		63.5	61	59	57.5	56	54.5	53	49	45.5	42	39
CDL150-30	37	50		78	76.5	75	73	70.5	68	66	63	59	55	50.5
CDL150-40-1	45	60		96.5	94	91.5	89	86.5	84	81.5	77	72.5	67	62
CDL150-50-2	55	75		115.5	112	109	106	102.5	100	97	92	86	79	73.5
CDL150-60	75	100		157	153	149	145	142	139.5	137	130	123.5	116	109

● Installation sketch

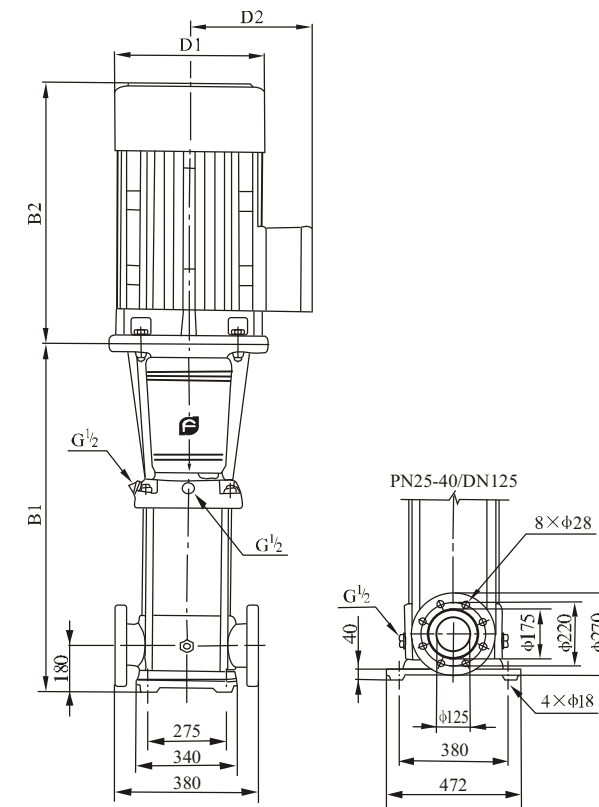

● Size and weight

Model	Size (mm)					Weight (kg)
	B1	B2	B1+B2	D1	D2	
CDL150-10-1	840	490	1330	330	255	230
CDL150-10	840	490	1330	330	255	235
CDL150-20-1	1000	590	1590	360	285	295
CDL150-30-2	1160	660	1820	400	310	360
CDL150-30	1160	660	1820	400	310	385
CDL150-40-1	1320	700	2020	460	340	460
CDL150-50-2	1510	770	2280	540	370	570
CDL150-60	1670	845	2515	580	410	700

The overall dimensions of the single-phase motor and explosion-proof motor are a little different. Pls contact us for details.

CNP India
NANFANG PUMPS INDIA PVT. LTD.
Address: 103,Kasturi Tower, 238/A, L.B.S Marg, Opp.Red Cross Bhavan,
Thane-400 602, India.
Tel : +91-22-2542 5540
Fax: +91-22-2542 7306
E-mail: sales@nanfangpumps.com
Website: <http://www.nanfangpumps.com>

CNP Indonesia
PT SOUTHERN INDONESIA (Lindeteves Trade Centre)
Address:Blk RA No 56-57,JI Hayam Wuruk 127,Jakarta 11180,Indonesia
Tel: +62 21 62200955 / 30012832
Fax: +62 21 62201026 / 30064055
E-mail: info@southernindonesia.com
Website: <http://www.southernindonesia.com>

CNP Malaysia
IKHUA ENGINEERING SDN.BHD.
Address: Plot F, Lot 1998, Jalan Perusahaan Tiga, Taman Selesa Jaya,
43300 Balakong, Selangor Darul Ehsan, Malaysia.
Tel: 603-8961 6858 (Hunting Line)
Fax: 603-8961 3118
E-mail: ikhuaengrg@pd.jaring.my
Website: <http://www.ikhua.com.my>

